



# PRODUCT CATALOGUE 2026



VALID  
FROM  
JAN26

# MOVAX WAY TABLE OF

<b>MOVAX WAY-OF-PILING</b>	
Introduction	4
Piling and foundation equipment	6
Customised solutions	8

---

<b>MOVAX WAY-OF-PILING</b>	10
----------------------------	----

---

<b>SIDE GRIP VIBRATORY PILE DRIVERS</b>	
Introduction	12
Technology	14
Features	17
Selection	18
Variable Active	20
MOVAX modular system	20
Modular arms	22
Tube arms	23
Bottom clamp	24
Technical data	26
Fixed Eccentric & Resonance free	28
MOVAX modular system	28
Sheet pile arms	30
Tube arms	31
Modular arms	32
Bottom clamp	34
Technical data	36
Fixed Eccentric (LITE)	38
MOVAX modular system	38
Modular arms	40
Bottom clamp	42
Technical data	44
Fixed Eccentric (SGL)	46
MOVAX modular system	46
Technical data	48

---

<b>PILING HAMMERS</b>	
Introduction	51
Features	53
Mounting options	54
Pile handler	56
Selection	58
Pile caps	59
Technical data	60

---

<b>PILING DRILLS</b>	
Introduction	62
Features	65
Technical data	
Models KB	66
Models TAD	68

---

<b>PRE-AUGERS</b>	48
Features	48
Technical data	48

---

<b>MANIPULATORS</b>	
Introduction	71
Features	73
MOVAX modular system	74
Technical data	75



RAIL



ROAD



PIERS &  
WATERWAYS

# Y-OF-PILING CONTENTS



<b>MULTI-TOOL PILING LEADERS</b>	
Introduction	76
Features	79
MOVAX modular system	80
Selection	82
Technical data	84
Tooling	
Piling hammer	86
Vibratory pile driver	88
Pre-auger rotary drive	90
CFA rotary drives	92
Rotary drive for DTH	94
Vibrolance	96
<hr/>	
<b>SOIL IMPROVEMENT LEADERS</b>	
Introduction	99
Column stabilisation leader, MSL	100
Monitoring & reporting	102
Jet grouting leader, MJL	104
<hr/>	
<b>MOVAX CONTROL SYSTEM</b>	
Introduction	107
Features	109
mControl+ PRO	
Introduction	110
Features	111
Automatic control	112
Information	114
mControl+ LITE	
Introduction	116
Features	117
<hr/>	
<b>INFORMATION MANAGEMENT</b>	
Introduction	118
mFleetManagement	120
mLogbook	125
Project reports	126
Pile reports	130
<hr/>	
<b>ADAPTERS</b>	134
<hr/>	
<b>QUALITY</b>	137
<hr/>	
<b>SERVICES</b>	
mFleetCare	139
Globally local support	141
<hr/>	
<b>BENEFITS</b>	142



UTILITIES



ENERGY &  
ENVIRONMENT



CIVIL

 **MOVAX**.com

# INTRODUCTION

Movax Oy, established in 1993, is a Finnish-based, world-leading innovator, developer and manufacturer of excavator-mounted piling and foundation equipment with highly advanced automatic control systems and information management solutions.

Movax Oy is the inventor of the modular, vibratory side grip pile driver technology. Movax Oy's inventions have resulted in numerous patents (50+) and its trademark, MOVAX®, is registered and well known for the quality it represents all over the world.

Movax Oy is strongly committed to continuously develop its products and services in close cooperation with its customers and local partners.



**1993**

Established in Hämeenlinna, Finland

**1996-1997**

1<sup>st</sup> auto-steering for hydraulic excavator

**2009**

ISO 9001 certificate

**2012**

Resonance-free side grip pile driver

**2015**

1<sup>st</sup> DH piling hammers  
1000<sup>th</sup> delivery

**1994**  
1<sup>st</sup> side grip pile driver

**2006**  
New factory in Hämeenlinna

**2011**  
New generation modular side grip (SG) pile driver

**2014**  
Introduction of new generation MCS Lite & Pro Control Systems

## MAJOR MILESTONES

## A TOTAL SOLUTION

Movax Oy focuses solely on solutions for the piling & foundation industry. The comprehensive range of excavator-mounted piling & foundation equipment and customized solutions cover a complete range of piling technologies - including both driven and bored piles.

## UNIQUE, VALUE-ADDING TECHNOLOGY

Movax Oy's piling and foundation equipment provide the optimum way-of-working - MOVAX WAY-OF-PILING™ - when constructing foundations, building retaining walls, both temporary and permanent, cofferdams and when performing trenching and excavation work and soil stabilisation in a wide range of applications.

## GLOBALLY LOCAL CUSTOMER CARE

Movax Oy focuses on superior customer service and support together with a world-wide network of local partners, established in more than 30 countries all over the world.

## GLOBALLY PROVEN

With more than 30 years of experience and more than 3000 units delivered to all over the world, MOVAX has a deep understanding and know-how of varying site and soil conditions - and of all kinds of different type of excavators and rail roaders.

Movax Oy's experience also covers a wide range of applications ranging from Rail, Road and Civil to Waterways & Piers, Utilities and Environmental & Energy.

## QUALITY BUILT-TO-LAST

MOVAX is made with high-class materials, equipment and components – and modern, state-of-the-art production technologies ensuring the highest possible quality - and availability.

Movax Oy's Quality Management Systems is certified in accordance with ISO 9001; and MOVAX Oy's products with the CE and UKCA marking.

# **MOVAX** way-of-piling™

Higher productivity – Significant savings  
fast. efficient. versatile. safe. accurate. reliable.

**2017**

1<sup>st</sup> MPM manipulator



**2020**

1<sup>st</sup> MPL  
Multi-tool piling  
leader with CFA  
rotary drive



**2022**

Introduction of next generation mControl+™  
Control System with autoT™ (tip control)

1<sup>st</sup> MPL-multi tool piling leader with DTH



**3000**

**2024**

Variable active  
side grip pile drivers  
SG-45VA, SG-50VA  
& SG-65VA



**2019**

MCS for electronically controlled  
excavators

MOVAX Information Management  
System with mLogbook™ and  
mFleetManagement™

1<sup>st</sup> KB kelly-bar piling drill

1<sup>st</sup> MPL multi-tool piling leader with  
pre-auger rotary drive

**2021**

1<sup>st</sup> MPL-multi-tool piling leader  
with TG vibratory pile driver

MCS with CAN bus control

KB kelly bar piling drill  
with 20 m drilling depth

**2023**

Introduction of nextGeneration  
side grip pile driver with  
variable active moment, SG-80VA

Introduction of side grip pile driver for  
photovoltaic (solar) power plants/o-,  
H-, sigma- and c-profiles, SGL-15N

**2025**

1<sup>st</sup> MPL  
Vibrolance

## INTRODUCTION

# PILING & FOUNDATION EQUIPMENT

MOVAX excavator mounted piling equipment are available for varying site conditions and requirements and for different piling technologies, including driven and bored piles.

MOVAX side grip vibratory pile drivers are suitable for all kinds of piles including sheet piles, H-beams, tubular steel piles, timber piles and MOVAX piling hammers furthermore for precast concrete piles. MOVAX piling drills are used cast-in-situ, concrete piling.



### SIDE GRIP PILE DRIVERS

**SIDE GRIP PILE DRIVERS (SG)** are the optimum solution for a wide range of piling requirements and a variety of site and soil conditions – especially when a high-degree of precision is required, and for piling in sensitive environments and when limited space or access is available.

The same unit can handle, pitch and drive piles and is capable of accomplishing the whole process without the need of manual handling or assisting machinery.

### PILING HAMMERS

**Piling hammers (DH)** are utilised to drive load-bearing piles and to assist in sheet pile driving, even in the most difficult soil conditions. MOVAX piling hammers are the optimum solution to complete a pile installation after reaching refusal with a side grip pile driver or when load testing is required.

The piling hammers can be mounted directly onto the excavator, onto MOVAX Multi-tool piling leader, or a third-party piling rig or crane.

### PILING DRILLS

**Piling drills (TAD/KB)** are designed for cast in-situ and other earth-removal tasks; and the KB-model also for cased drilling.

MOVAX piling drills are especially suitable for sites with confined spaces and when limited space or headroom is available.



## MANIPULATORS

**Manipulators (MPM)** are designed for fast, flexible and efficient handling of different kinds of masts, gantries, and poles as well as a wide range of piles. Soft gripping surfaces are available to prevent damage of sensitive surfaces or coatings.

The MOVAX manipulator is designed for superior maneuverability, safety, precision and accuracy.

## PRE-AUGERS

**Pre-augers (PA)** are utilised to support vibratory and impact pile driving in challenging soil conditions by softening the ground prior to the pile driving.

Pre-augering is also utilized to ensure that, for instance, sheet piles can be extracted.

## CONTROL



The **MOVAX Control System (mControl+)** links the excavator with MOVAX's piling equipment. The system controls the auxiliary hydraulics of the excavator and all the functions of MOVAX's piling equipment.

## INFORMATION



### MOVAX Information Management System (MIMS)

**mLogbook** provides a tool to efficiently monitor and report the piling works saving both time and cost.

**mFleetManagement** is utilised to monitor the MOVAX piling equipment thus ensuring maximum availability.

## INTRODUCTION

# CUSTOMISED PILING & FOUNDATION and SOIL IMPROVEMENT SOLUTIONS

MOVAX customised solutions are available for different piling technologies, including driven, bored and drilled piles, and for soil improvement.

MOVAX customised solutions are excavator mounted leaders equipped with wide range of tooling tailored to meet customer specific requirements.

### MULTI-TOOL PILING LEADERS

**MOVAX Multi-tool piling leaders (MPL)** are a multi-purpose piling leaders designed for medium to large size excavators.

Tooling alternatives include vibratory pile drivers, hydraulic impact type hammers, hydraulic hammers (rock breakers) and rotary drives for pre-augering, CFA (continuous flight auger) and DTH (down-the-hole) piling.



## SOIL IMPROVEMENT LEADERS

**MOVAX Soil Improvement Leaders** are available for dry binder material (Column stabilisation, MSL) and wet binder material (Jet grouting, MJL). The column stabilisation and jet grouting leaders are utilizing medium to large size excavators as the carrier.



## CONTROL



The **MOVAX Control System (mControl+)** links the excavator with MOVAX's customised solutions. The system controls the auxiliary hydraulics of the excavator and all the functions of the leader and its tooling; and the soil improvement leader.

## INFORMATION

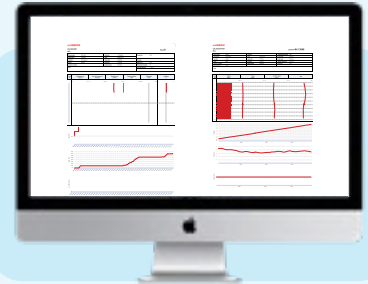

**mLogbook** provides a tool to efficiently monitor and report the piling and soil stabilisation works saving both time and cost.

**mFleetManagement** is utilised to monitor the MOVAX piling equipment thus ensuring maximum availability.

# MOVAX WAY-OF-PILING



RAIL



ROAD



UTILITIES



ENERGY & E  
incl. SOLAR



CIVIL



ENVIRONMENT



PIERS & WATERWAYS

## INTRODUCTION

# SIDE GRIP TECHNOLOGY

MOVAX Side grip pile drivers are excavator-mounted, high-frequency, vibratory-type pile drivers providing the optimum solution for a wide range of piling requirements – especially when a high degree of precision is required; and for piling in sensitive environments and when limited space, head room or access is available.



## HANDLING

### HIGHER PRODUCTIVITY – SIGNIFICANT SAVINGS

Efficient. Fast. Versatile. Accurate. Safe. Reliable.

The same unit can handle, pitch and drive – and extract – different type of piles and is capable of accomplishing the entire piling process without the need of manual handling or assisting machinery. Furthermore there is no need for additional work, material and tools.



MOVAX mControl+ control system ensures a fast, efficient, accurate and safe pile driving process leading to higher productivity and quality.



PITCHING

DRIVING/EXTRACTING

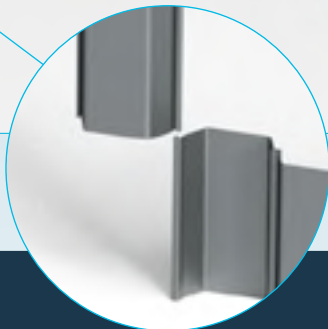

# INTRODUCTION

## VIBRATORY PILE DRIVER TECHNOLOGY

Vibratory pile drivers work by reducing the resistance and formation of the ground by the means of vibration. Vertical vibrations are transferred from the vibratory pile driver to the pile via a hydraulic arm or clamp (gripping the pile).

The vibration then travels from the pile to the soil, thus reducing the friction between the pile and the ground allowing the pile to be driven or extracted with less force. The pile is driven to the ground by a combination of the vibrator's weight, centrifugal force it produces and the downward force put out by the excavator.

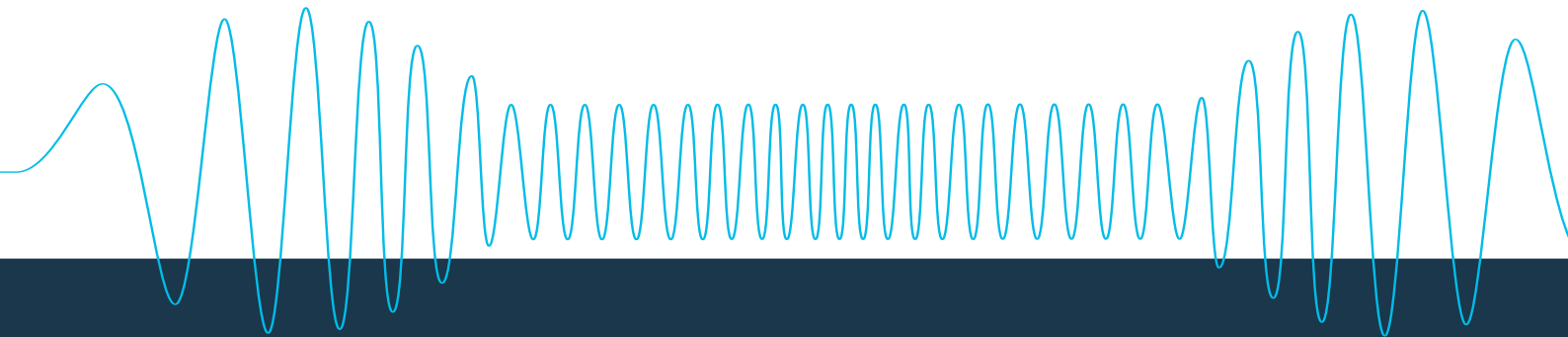
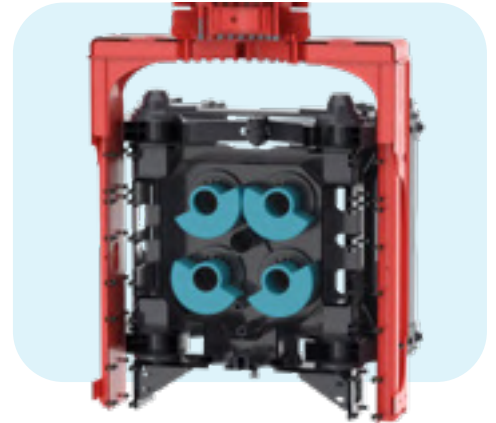

### MOVAX side grip vibratory pile drivers

MOVAX invented the side grip technology in 1993. Since the first fixed eccentric model designed primarily to handle and drive sheet piles the MOVAX side grip pile driver have over the years developed to a versatile modular design side grip pile driver capable of handling a wide range of different type of piles from sheet piles and H-beams to tubular steel piles, trench sheets and timber piles. The resonance-free technology was introduced to allow operation in sensitive conditions. The nextGeneration, variable active, side grip pile driver introduced in 2023 takes the technology yet again to the next level in efficiency and performance.

**1993**

Established in Hämeenlinna, Finland

**1995-2000**

SP-40, SP-50:  
B, C and D-models

**2006-2012**

SP-50, SP-60:  
F-models

**1994**

1<sup>st</sup> side grip pile driver,  
UV-50/UV-75

**2000-2007**

SP-40, SP-50, SP-60:  
E-models

**2011-2013**

new Generation  
modular side grip  
(SG) pile driver

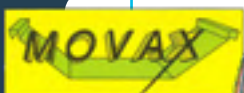



**2012-2015**

Resonance-free modular (SG-V) side grip pile driver



**2016-2017**  
SG face-lift

**2018-2020**

SG-LITE (N) series



**2023**  
next generation  
Variable Active (SG-VA)  
side grip pile driver:  
SG-80VA

**2023-2024**

SGL-15N for solar power plants  
(o-, H-, sigma- and c-profiles)



**2024-2025**

NextGen variable active  
side grip pile drivers  
SG-45VA, SG-50VA & SG-65VA



# INTRODUCTION

## VIBRATORY PILE DRIVER TECHNOLOGY

The nature of vibration is to move through matter - everything has its natural resonance, i.e. the frequency in which they have a tendency to vibrate and oscillate. In order to avoid oscillation and thus disturbances to the surroundings, including the ground itself, buildings and structures, it is recommendable to avoid vibrating at natural frequencies.

Vibratory pile drivers are designed for operation at either a high frequency (HF) typically above 38 Hz/2300 RPM or at a low frequency (LF) typically below 24 Hz/1700 RPM.

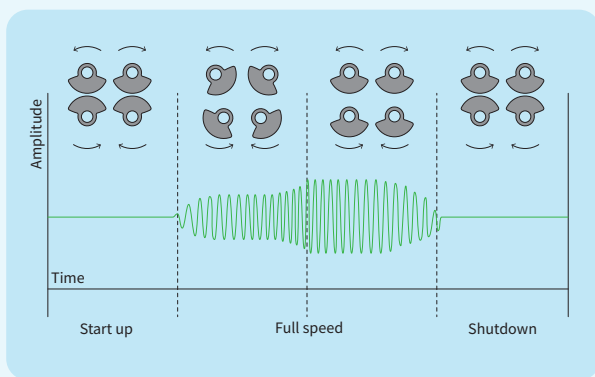

### Variable active eccentric moment

The variable active technology allows the adjustment of the eccentric moment - and thus the amplitude - during pile driving or extraction. The variable active moment optimizes the use of the excavator's hydraulic power by maintaining the highest possible force in challenging soil conditions and preventing the formation of resonance frequencies throughout the piling process. The start-up and shutdown of variable active type vibratory pile drivers are resonance free, thus minimizing any disturbances to the surrounding soil or structures.

### Resonance-free

The resonance-free technology allows for starting up and shutting down the side grip pile driver without vibration. This is achieved for instance by shifting the upper row eccentrics in respect to the lower row eccentrics. The total eccentric moment of resonance free type vibratory pile drivers can be switched from 0% during start-up to 100% during operation and back to 0% during shut down thus minimizing any disturbances to the surrounding soil or structures.

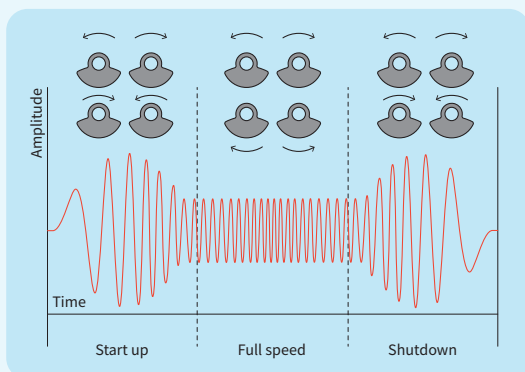
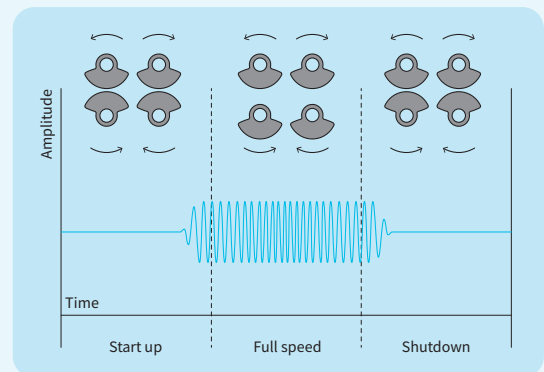

### Fixed eccentric moment

**Fixed eccentric** vibratory pile drivers are either high frequency (2300-3000 rpm/38- 50 Hz) or low frequency (24 Hz/1700 rpm) vibratory pile drivers. The fixed eccentric moment pile drivers are suitable for a wide range of piling works in different site and soil conditions when there is no need to minimize disturbances to the surroundings.





# SIDE GRIP VIBRATORY PILE DRIVERS

## FEATURES

### EXCAVATOR-MOUNTED

- Suitable for 7-50 ton excavators.
- Utilizing the hydraulic power and lifting capacity of the excavator or rail roader (carrier).
- Designed to work on any and all wheeled and crawler-type excavators and rail roaders by utilising and commanding the standard auxiliary hydraulics and/or by connecting to the electronic control of the excavator.

### COMPREHENSIVE MODEL & SIZE RANGE

- Available in different models, sizes and configurations for different piling requirements and different type of piles ranging sheet piles, trench sheets and, H-beams to tubular steel piles and timber piles
- Available for excavators ranging from 7 to 50 ton – thus always ensuring the optimum size and correct combination of vibratory pile driver and excavator.

### HIGH FREQUENCY

- High frequency HF (2300-3000 rpm / 38-50 Hz) vibratory pile driver
- Specifically designed to be used with an excavator or rail roader as carrier.

### STATE-OF-THE ART VIBRATION TECHNOLOGY

- Variable eccentric moment (VA-models) for optimum performance under all site and soil conditions. VA -models are also resonance-free under all operating conditions.
- Available also with fixed eccentric moment (STD/LITE) or with resonance-free start/stop (V)

### MOVAX MODULAR SYSTEM

- Versatility based on the MOVAX Modular System™ which enables the use of the same unit for a wide range of different piling requirements, piling work and type of piles.
- Optional handling clamps available for U- & Z-piles.

### MOVAX CONTROL SYSTEM

- MOVAX Control System, mControl+
  - mControl+ LITE
  - mControl+ PRO with automatic tip-control for maximised productivity and quality.
- For VA-models: Advanced, real-time monitoring of
  - Clamping pressure (*electronically monitored, actual pressure of all individual cylinders*)
  - Gear oil pressure
  - Gear oil temperature

### MOVAX INFORMATION MANAGEMENT SYSTEM

- mFleetManagement for monitoring MOVAX piling equipment operation, performance and condition.
- mLogbook for monitoring and reporting the piling works.



### HANDLING, PITCHING, DRIVING AND EXTRACTING



# SIDE GRIP VIBRATORY PILE DRIVERS

## SELECTION

The optimal MOVAX side grip pile driver for a specific piling & foundation application is selected based on the following:

- technology (variable active, resonance-free, fixed eccentric)
- excavator brand and model
- soil & site conditions
- pile dimensions (weight & length/diameter)



The configuration i.e. the arms, clamps and/or pads of the MOVAX side grip pile driver are then selected based on the type of piles to be driven.



### Model (technology)

MOVAX side grip vibratory pile driver-models are available based on three different (vibro)technologies: variable eccentric moment (VA), resonance-free (V) and with fixed eccentric moment (STD/LITE). MOVAX side grip vibratory pile drivers are available with variable active moment, resonance-free start/stop (V) and with fixed eccentric moment.

**Variable Active (VA)** models are selected for the most demanding applications and for sensitive areas where disturbances to the surroundings are to be minimized.

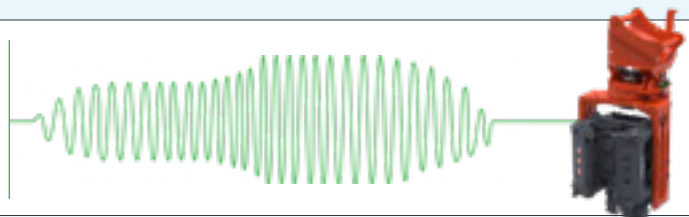

**Resonance-free (V)** models are selected for sensitive areas where disturbances to the surroundings are to be minimized.

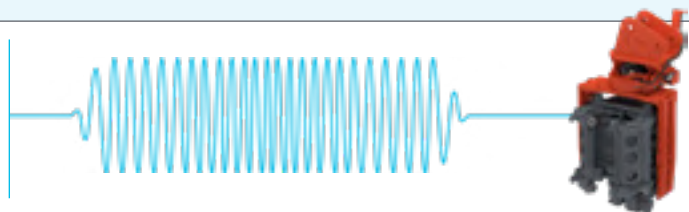

**Fixed eccentric (LITE & STD)** models are selected for a wide range of piling jobs.

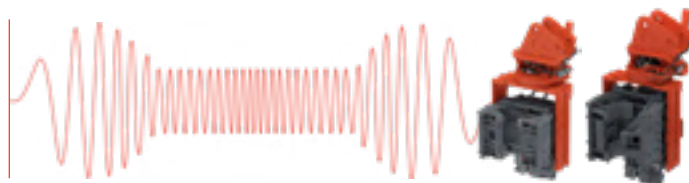

## PRODUCT RANGE

# SIDE GRIP PILE DRIVERS

### Excavator (brand & model)

The excavator must be suitable – and match – the specific vibratory pile driver in question in regards to hydraulic power (oil flow @ pressure). Thus the excavator brand & model is needed for the correct selection of model.

### Type & dimension of piles

In order to select the correct MOVAX model, the type of piles (sheet pile, H-beam, tubular steel pile and/or timber pile) and their dimensions (length, width/depth, OD) are needed.

The arms, clamps and pads are selected based on the piles to be driven. Due to the modular design (*MOVAX Modular System*) the same MOVAX side grip pile driver can be used to drive different type of piles.

### Soil conditions

Vibratory pile drivers are suitable for a wide range of soil conditions & N-values (SPT). In order to make a detailed analysis of the suitability of a MOVAX model for a specific project a soil report is needed.

### Site conditions

MOVAX side grip pile drivers are the optimum solution for sites with limited access, space or headroom. Standard (STD) and Lite models are selected for a wide range of piling jobs. Variable active (VA) and Resonance-free (V) models are selected for sensitive areas where disturbances to the surroundings are to be minimized.

## SELECTION CHART

EXCAVATOR CLASS/	33-50 t	28-32 t	23-28 t	20-24 t	17-21 t	13-16 t	7-11 t
<b>PILE SIZE (length x weight)</b>							
6 m x 2800 kg 12 m x 1900 kg 16 m x 1300 kg	<b>SG-80VA</b> <b>SG-75V</b> <b>SG-75</b>						
8 m x 2300 kg 12 m x 1800 kg 16 m x 1200 kg		<b>SG-65VA</b> <b>SG-60V</b> <b>SG-60</b>	<b>SG-50VA</b> <b>SG-50V</b> <b>SG-50</b>	<b>SG-45VA</b> <b>SG-45V</b> <b>SG-45</b>			
6 m x 1200 kg 12 m x 1000 kg 16 m x 900 kg					<b>SG-40N</b> <b>SGL-15N</b>	<b>SG-30N</b> <b>SGL-15N</b>	
4 m x 400 kg 6 m x 200 kg							<b>SG-15N</b>
<b>SUITABLE PILES</b>							
Sheet piles / trench sheets		width 400-1200 mm			width 400-1200 mm		width 400-600 mm
H-beams		H100-H500			H100-H400		H100-H140
Timber piles		Ø160-600 mm			Ø120-325 mm		Ø100-200 mm
Tube piles		Ø88.9-1220 mm			Ø88.9-508 mm		Ø88.9- 323.9 mm

The Selection Chart provides the preliminary selection; When making the final selection the excavator engine size and hydraulic system design (oil pump arrangement, oil flow rate/pressure etc.), excavator lifting capacity and stability and soil and site conditions shall be taken into account.

# SIDE GRIP VIBRATORY PILE DRIVERS

## MOVAX MODULAR SYSTEM

### Variable Active (VA)

The MOVAX Modular System (MMS™) enables the use of the same MOVAX side grip pile driver for a wide range of different type of piles ranging from sheet piles, H-beams and tubular steel piles to timber piles.

The MOVAX Modular System includes interchangeable arms, clamps and pads that can easily and efficiently be changed for the different pile types in question.

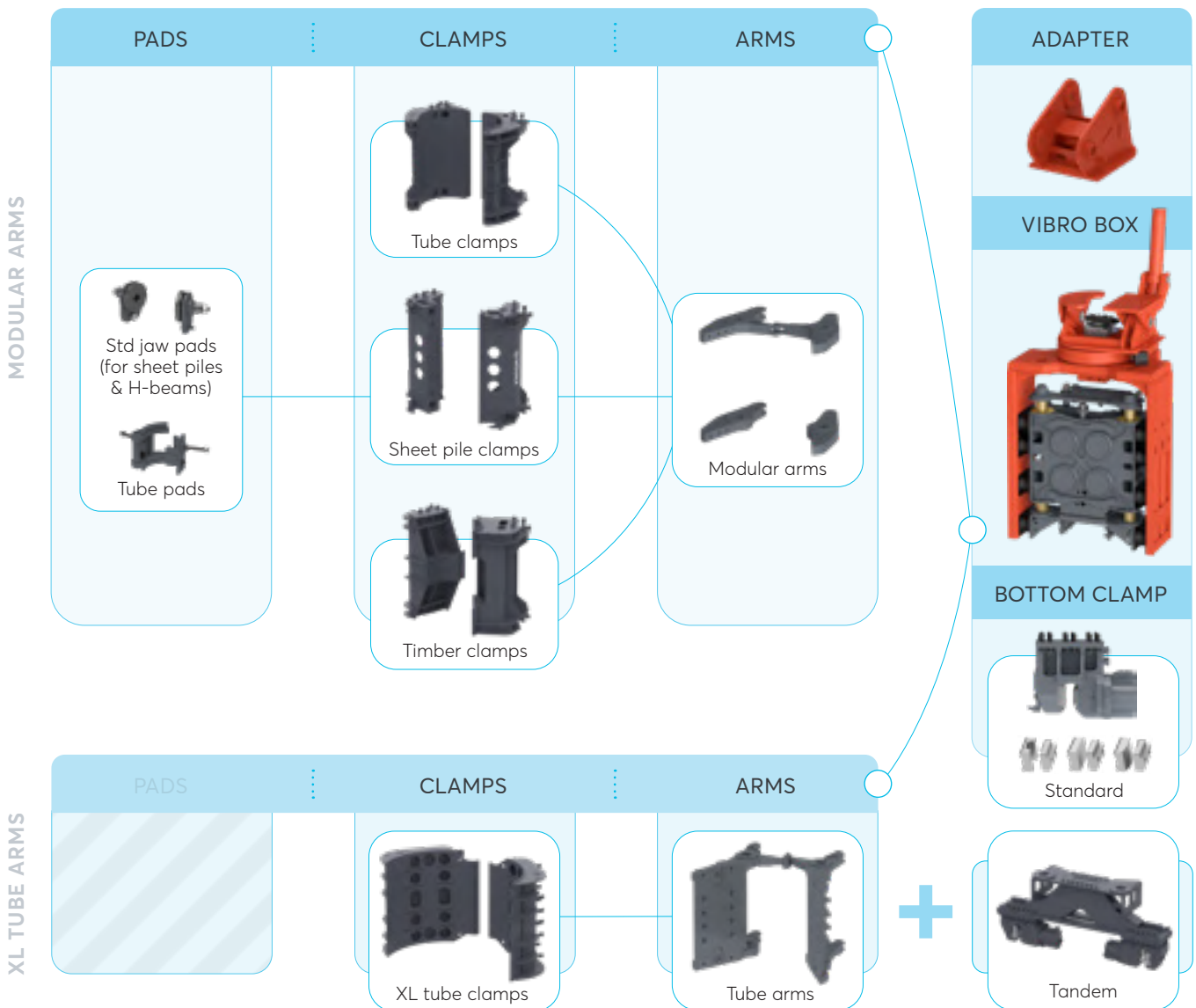

# SIDE GRIP VIBRATORY PILE DRIVERS

## MOVAX MODULAR SYSTEM

### Variable Active (VA)

#### MODULAR ARMS

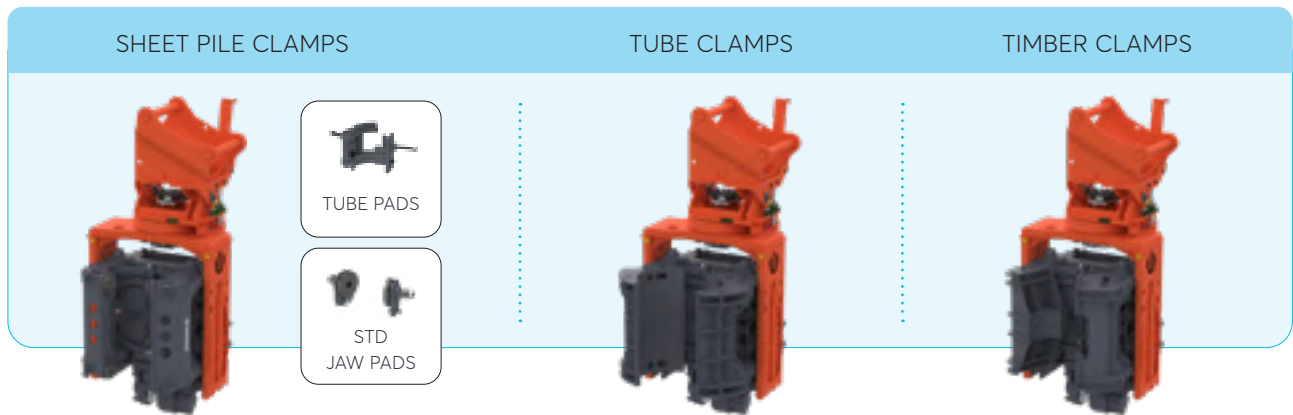

#### TUBE ARMS

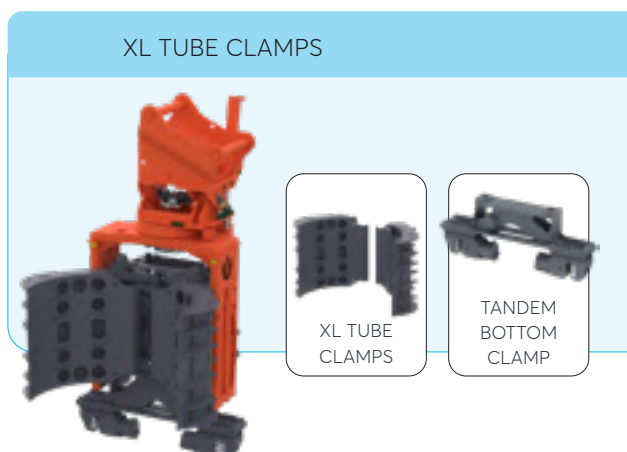

# SIDE GRIP VIBRATORY PILE DRIVERS

## MODULAR ARMS

### Variable Active (VA)

**Modular arms** are suitable for driving sheet piles, H-beams, tubular steel piles and timber piles.

**Sheet pile clamps** are utilised to drive sheet piles and H-beams. The sheet pile clamps can be equipped with tube pads for tubular steel piles up to OD 273 mm. Each tube size requires its own tube pads in order to ensure proper operation.

**Tube clamps** are utilised for tubular steel piles up to OD 762 mm. Each tube size requires its own tube clamps of matching size.

**Timber clamps** are utilised to drive timber or wooden piles. A range of round timber piles can be driven with the same timber clamps whereas square timber piles requires clamps of the same size.



#### TUBE CLAMPS

for tubular steel piles from  
OD 88.9 mm up to OD 762 mm:

##### Standard sizes

Ø 88.9	Ø 168.3	Ø 457
Ø 101.6	Ø 219.1	Ø 508
Ø 114.3	Ø 273	Ø 610
Ø 127	Ø 323.9	Ø 711
Ø 139.7	Ø 406.4	Ø 762



#### SHEET PILE CLAMPS

Sheet pile/H-beam  
w 400-1200 mm/H180-H500

Tube piles up to OD 273

##### Standard sizes

Ø 88.9	Ø 114.3	Ø 139.7	Ø 219.1
Ø 101.6	Ø 127	Ø 168.3	Ø 273



#### TIMBER CLAMPS

for timber piles from  
OD 160 mm up to 600 mm

A range of timber pile sizes can be  
driven with the same timber clamps.

##### Standard sizes

M Ø 160-420 mm
L Ø 430-600 mm

Customised sizes and special types, for instance for rail tracks, are available by request.

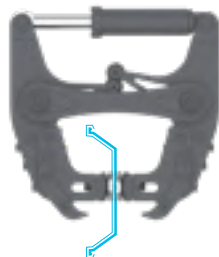

# SIDE GRIP VIBRATORY PILE DRIVERS

## TUBE ARMS

### Variable Active (VA)

Special modular tube arms are utilised to handle and drive large diameter tubes from 508 mm up to OD 1220 mm. Each tube size requires its own tube clamp of the same size as the tube in order to ensure proper operation.

A tandem bottom clamp is available for the same tube sizes as the tube arms for optimised pile driving of large tubes. The same tandem bottom clamp can be used for the range of the different size tubular steel piles.



**XL TUBE CLAMPS**  
from OD 508 to 1220mm

Standard sizes

Ø 508	Ø 711	Ø 813	Ø 1016
Ø 610	Ø 762	Ø 914	Ø 1220



**TANDEM BOTTOM CLAMP**

Tube pads for tandem bottom clamp  
from OD 508 mm up to OD 1220 mm.

**TUBE ARMS** are designed for the optimum handling, pitching and driving/  
extraction of large OD tubes.



# SIDE GRIP PILE VIBRATORY DRIVERS

## BOTTOM CLAMP incl. options

### Variable Active (VA)

The (standard) bottom clamp is utilised for the completion of the pile driving and is suitable for all kinds of piles including sheet piles, H-beams and tubular steel piles.

The bottom clamp is equipped with pads for the specific pile type in question, Sheet pile pads are utilised for sheet piles and H-beams, Double (sheet) pile pads are recommended when driving double sheet piles (both U and Z). Tube pads are available in two sizes, from OD 323,9 mm to 508 mm and OD 508 mm to OD 762 mm; both covering the entire range as specified.

Smaller OD tube piles (from 88,9 mm to 323,9 mm and timber piles require a top hitter. The same top hitter is suitable for the entire range.

An optional handling jaws can be provided for added pile handling capabilities.



#### Top hitter (optional)

Smaller OD tube piles and timber piles require a top hitter. The same top hitter is suitable for the entire range.

Top hitters for larger OD piles and f. ex. square timber piles are available by request.



#### Lifting lever

The bottom clamp is equipped with a lifting lever for handling of sheet piles.

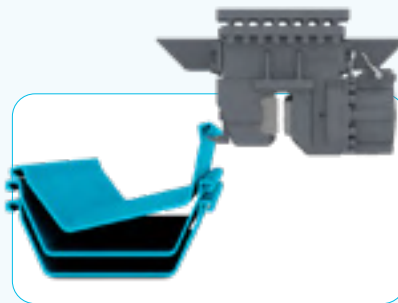

#### Handling jaws (optional)

Handling jaws are available with different type of inserts for optimised gripping of different type of pile profiles (both sheet piles and smaller OD tube pile piles).

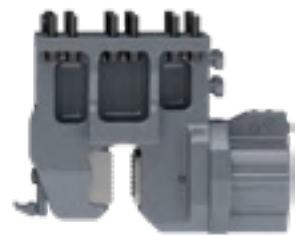

Sheet pile pads



Tube pads  
OD 323,9...508 mm  
OD 508...762 mm



Double (sheet)  
pile pads  
Available for  
double-Z type  
sheet piles

# SIDE GRIP VIBRATORY PILE DRIVERS

## TECHNICAL DATA

### Variable Active (VA)

Model		SG-80VA	SG-65VA	SG-50VA	SG-45VA
Weight (with sheet pile clamps, excl. adapter)	kg	3210	2810	2500	2490
Height	mm	2860	2840	2840	2840
Depth	mm	1295	1295	1295	1295
Width	mm	1230	1170	1170	1170
Frequency		38-50 Hz (2300-3000 RPM)			
Eccentric moment (max)	kgm	8,1	6,6	5,1	4,6
Centrifugal force (max)	kN	800	650	500	450
Ground vibration		Minimal			
Resonance free start/stop		Yes			
Active variable eccentric moment		Yes			
Swing/tilt angle	°	360/±45			
Pile length/weight		6 m / 2800 kg 12 m / 1900 kg 16 m / 1300 kg	8 m / 2300 kg 12 m / 1800 kg 16 m / 1200 kg	8 m / 2300 kg 12 m / 1600 kg 16 m / 1200 kg	
Return pressure	bar	5			
Pressure setting	bar	350			
Excavator class	t	33-50	28-32	23-28	20-24
Engine power, min., TIER III	kW	180	135	125	100
Engine power, min., TIER IV	kW	200	160	135	120



# SIDE GRIP VIBRATORY PILE DRIVERS

## MOVAX MODULAR SYSTEM

Resonance-free (V) & Fixed eccentric

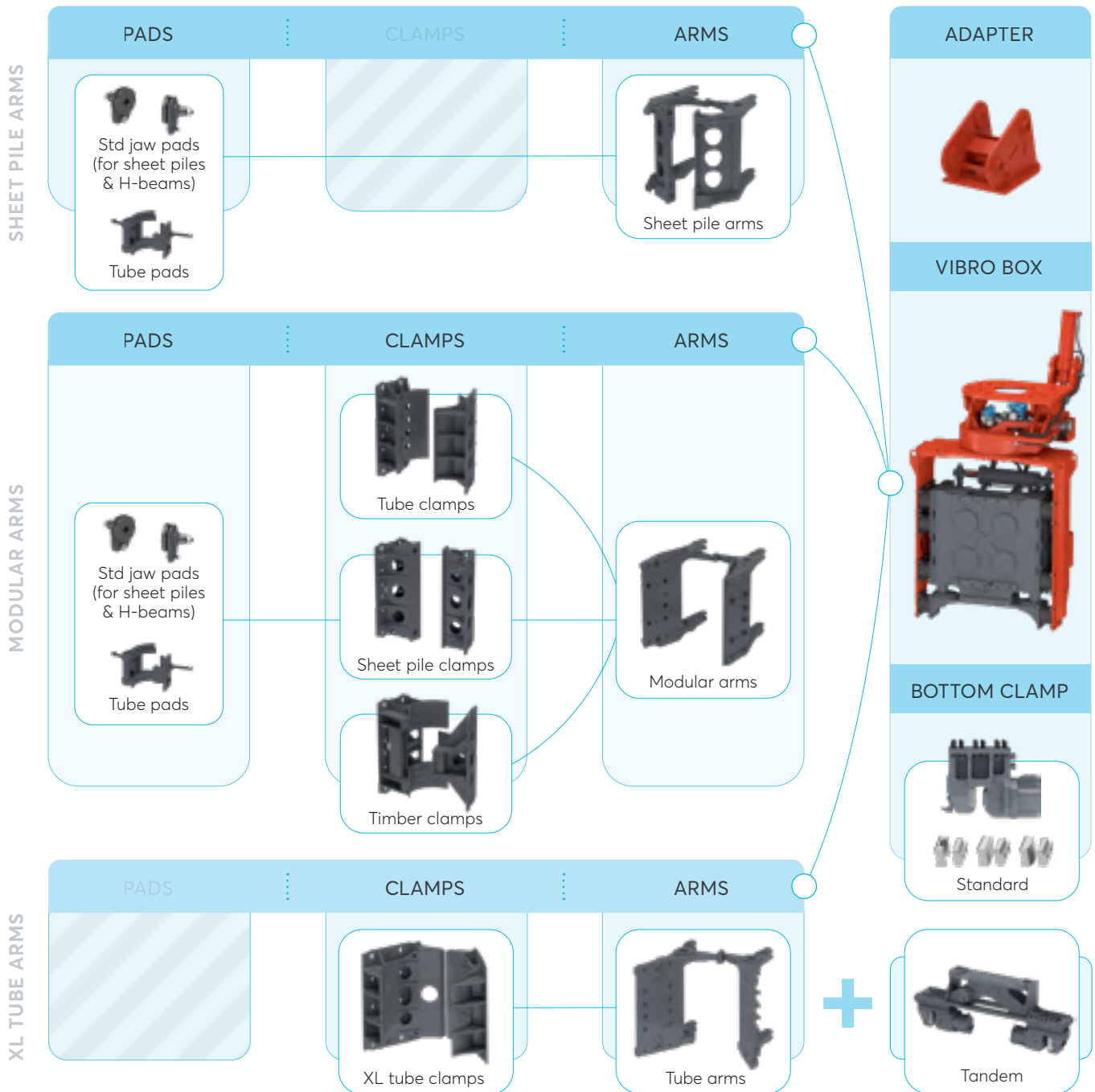

# SIDE GRIP VIBRATORY PILE DRIVERS

## MOVAX MODULAR SYSTEM

Resonance-free (V) & Fixed eccentric

### SHEET PILE ARMS

#### SHEET PILE CLAMPS

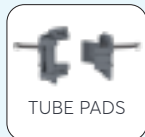

### MODULAR ARMS

#### SHEET PILE CLAMPS

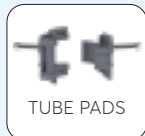

#### TUBE CLAMPS



#### TIMBER CLAMPS



### TUBE ARMS

#### XL TUBE CLAMPS



# SIDE GRIP VIBRATORY PILE DRIVERS

## SHEET PILE ARMS

### Resonance-free (V) & Fixed eccentric

Special sheet pile arms are the optimum solution when handling, pitching, driving and extracting only – or mainly – sheet piles and/or H-beams.

The special sheet pile arms can also be utilised to drive smaller diameter tubular steel piles or micropiles up to OD 273 mm. Each tubular steel pile size requires its own, individual tube pads.



**SHEET PILE PADS**  
for sheet piles and H-beams

**Standard sizes**  
w 400–1200 mm  
/ H180–H500



**TUBE PADS**

for tubular steel piles  
from OD 88.9 mm to OD 273 mm

**Standard sizes**

Ø 88.9	Ø 127	Ø 219.1
Ø 101.6	Ø 139.7	Ø 273
Ø 114.3	Ø 168.3	

Customised sizes and special types, for instance for rail tracks, are available by request.

**SHEET PILE ARMS** are designed for the optimum handling, pitching and driving/extraction of sheet piles, H-beams and tube piles.



Clamp hooks



Clamping the web



Handling, pitching,  
driving & extracting  
H-beams



Handling, pitching,  
driving & extracting  
sheet piles



Handling, pitching,  
driving & extracting  
small OD tube piles



# SIDE GRIP VIBRATORY PILE DRIVERS

## TUBE ARMS

### Resonance-free (V) & Fixed eccentric

Special modular tube arms are utilised to handle and drive large diameter tubes from 508 mm up to OD 1220 mm. Each tube size requires its own tube clamp in order to ensure proper operation.

A tandem bottom clamp is available for the same tube sizes as the tube arms for optimised pile driving of large tubes.



#### TUBE CLAMPS

for tubular steel piles from  
OD 508 mm to OD 1220 mm

##### Standard sizes

Ø 508	Ø 762	Ø 1016
Ø 610	Ø 813	Ø 1220
Ø 711	Ø 914	

Customised sizes are  
available by request.

#### TANDEM BOTTOM CLAMP



#### TUBE PADS

##### Standard sizes

Tube pads for tandem  
bottom clamp from  
OD 508 mm up to  
OD 1220 mm



**TUBE ARMS** are designed for the optimum handling, pitching and driving/extraction of large OD tubes.



Handling, pitching,  
driving & extracting  
large OD tube piles



Tandem bottom clamp  
driving/extracting  
large OD tube piles



## SIDE GRIP VIBRATORY PILE DRIVERS

# MODULAR ARMS

### Resonance-free (V) & Fixed eccentric

Modular arms are suitable for driving sheet piles, H-beams, tubular steel piles and timber piles.

Sheet pile clamps are utilised to drive sheet piles and H-beams. The sheet pile clamps can be equipped with tube pads for tubular steel piles up to OD 273 mm. Each tube size requires its own tube pads in order to ensure proper operation.

Tube clamps are utilised for tubular steel piles up to OD 762 mm. Each tube size requires also its own tube clamps.

Timber clamps are utilised to drive timber or wooden piles. A range of round timber piles can be driven with the same timber clamps whereas square timber piles requires clamps of the same size.





### TUBE CLAMPS

for tubular steel piles from  
OD 88.9 mm up to OD 762 mm:

#### Standard sizes

Ø 88.9	Ø 168.3	Ø 457
Ø 101.6	Ø 219.1	Ø 508
Ø 114.3	Ø 273	Ø 610
Ø 127	Ø 323.9	Ø 711
Ø 139.7	Ø 406.4	Ø 762



### SHEET PILE CLAMPS

for sheet piles and H-beams/  
tubular steel piles from OD 88.9 mm  
to OD 273 mm:

### SHEET PILE PADS

w 400–1200 mm/H180-H500



### TUBE PADS

#### Standard sizes

Ø 88.9	Ø 139.7
Ø 101.6	Ø 168.3
Ø 114.3	Ø 219.1
Ø 127	Ø 273



### TIMBER CLAMPS

for timber piles from  
OD 160 mm up to 600 mm:

A range of round timber pile sizes  
can be driven with the same  
timber clamps.

#### Standard sizes

M Ø 160-420 mm
L Ø 430-600 mm

In addition clamps for square  
timber piles are also available.  
Each square timber pile size  
requires clamps of matching size.

Customised sizes are available by request. (e.g. clamps for square timber piles or other special profiles).

**MODULAR ARMS** are designed for versatility and to handle, pitch, drive and extract  
sheet piles, tube piles or timber piles.



Handling, pitching,  
driving & extracting  
tube piles



Handling, pitching,  
driving & extracting  
sheet piles



Handling, pitching,  
driving & extracting  
small OD tube piles



Handling, pitching,  
driving & extracting  
timber piles



# SIDE GRIP VIBRATORY PILE DRIVERS

## BOTTOM CLAMP incl. options

### Resonance-free (V) & Fixed eccentric

The (standard) bottom clamp is utilised for the completion of the pile driving and is suitable for all kinds of piles including sheet piles, H-beams and tubular steel piles.

The bottom clamp is equipped with pads for the specific pile type in question, Sheet pile pads are utilised for sheet piles and H-beams, Double (sheet) pile pads are recommended when driving double sheet piles (both U and Z). Tube pads are available in two sizes, from OD 323,9 mm to 508 mm and OD 508 mm to OD 762 mm; both covering the entire range as specified.

Smaller OD tube piles (from 88,9 mm to 323,9 mm and timber piles require a top hitter. The same top hitter is suitable for the entire range.

An optional 4th jaw can be provided for added pile handling capabilities.

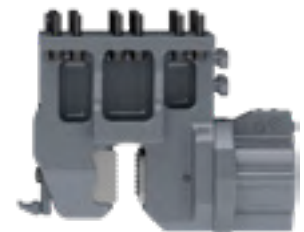

Sheet pile pads



Tube pads  
OD 323,9...508 mm  
OD 508...762 mm



Double (sheet)  
pile pads  
Available for double-Z  
type sheet piles

#### Top hitter (optional)

Smaller OD tube piles (from 88,9 mm to 323,9 mm and timber piles require a top hitter. The same top hitter is suitable for the entire range.

Top hitters for larger OD piles and f. ex. square timber piles are available by request.



#### Lifting lever

The bottom clamp is equipped with a lifting lever for handling of sheet piles.

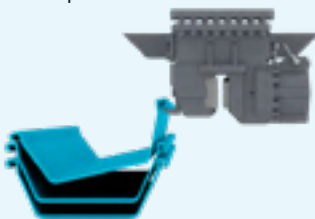

#### 4th jaw (optional)





# SIDE GRIP VIBRATORY PILE DRIVERS

## TECHNICAL DATA

### Resonance-free (V)

Model		SG-75V	SG-60V	SG-50V	SG-45V
Weight	kg	3500-3750	2650-2950	2500-2800	2490-2790
Height	mm	2615	2550	2530	2530
Depth	mm	1250-1600	1180-1435	1180-1435	1180-1435
Width	mm	1270	1193	1193	1193
Frequency	1/min	2300-3000	2300-3000	2300-3000	2300-3000
Eccentric moment	kgm	7,6	6,1	5,1	4,6
Centrifugal force, max	kN	750	600	500	450
Ground vibration		low			
Resonance-free start/stop		yes			
Driving method		vibration			
Swing/tilt angle	°	360/30	360/30	360/30	360/30
Return pressure, max	bar	5	5	5	5
Pressure setting	bar	350	350	350	350
Excavator class	t	33-50	28-32	23-28	20-24
Engine power, min. TIER III	kW	180	135	117	100
Engine power, min. TIER IV	kW	200	160	135	120

### Suitable piles

		6 x 2800 12 x 1900 16 x 1300	8 x 2300 12 x 1800 16 x 1200	8 x 2300 12 x 1800 16 x 1200	8 x 2300 12 x 1800 16 x 1200
Length & weight	m/kg				
Sheet piles, width	mm	400-1200			
Sheet piles, max. depth	mm	265			
H-beams	size	H100-H500			
Timber piles	mm	Ø160-420 Ø430-600			
Tubular steel piles, tubes	mm	Ø88.9-762 mm Ø508-1220 mm			



# SIDE GRIP VIBRATORY PILE DRIVERS

## TECHNICAL DATA

### Fixed eccentric

Model		SG-75	SG-60	SG-50	SG-45
Weight	kg	3330-3620	2550-2850	2400-2700	2390-2690
Height	mm	2615	2550	2530	2530
Depth	mm	1250-1600	1180-1435	1180-1435	1180-1435
Width	mm	1270	1193	1193	1193
Frequency	1/min	2300-3000	2300-3000	2300-3000	2300-3000
Eccentric moment	kgm	7,6	6,1	5,1	4,6
Centrifugal force, max	kN	750	600	500	450
Ground vibration		normal			
Resonance-free start/stop		no			
Driving method		vibration			
Swing/tilt angle	°	360/30	360/30	360/30	360/30
Return pressure, max	bar	5	5	5	5
Pressure setting	bar	350	350	350	350
Excavator class	t	33 - 40	28 - 32	23-28	20-24
Engine power, min. TIER III	kW	180	135	117	100
Engine power, min. TIER IV	kW	200	160	135	120

Suitable piles					
Length & weight	m/kg	8 x 2800	8 x 2300	8 x 2300	8 x 2300
		12 x 1900	12 x 1800	12 x 1800	12 x 1800
		16 x 1300	16 x 1200	16 x 1200	16 x 1200
Sheet piles, width	mm	400-1200			
Sheet piles, max. depth	mm	265			
H-beams	size	H100-H500			
Timber piles	mm	Ø160-420 Ø430-600			
Tubular steel piles, tubes	mm	Ø88.9-762 mm Ø508-1220 mm			



# SIDE GRIP VIBRATORY PILE DRIVERS

## MOVAX MODULAR SYSTEM

### Fixed eccentric (LITE)

The MOVAX Modular System (MMS™) enables the use of the same MOVAX side grip pile driver for a wide range of different type of piles ranging from sheet piles, H-beams and tubular steel piles to timber piles.

The MOVAX Modular System includes interchangeable clamps and pads that can easily and efficiently be changed for the different pile types in question.

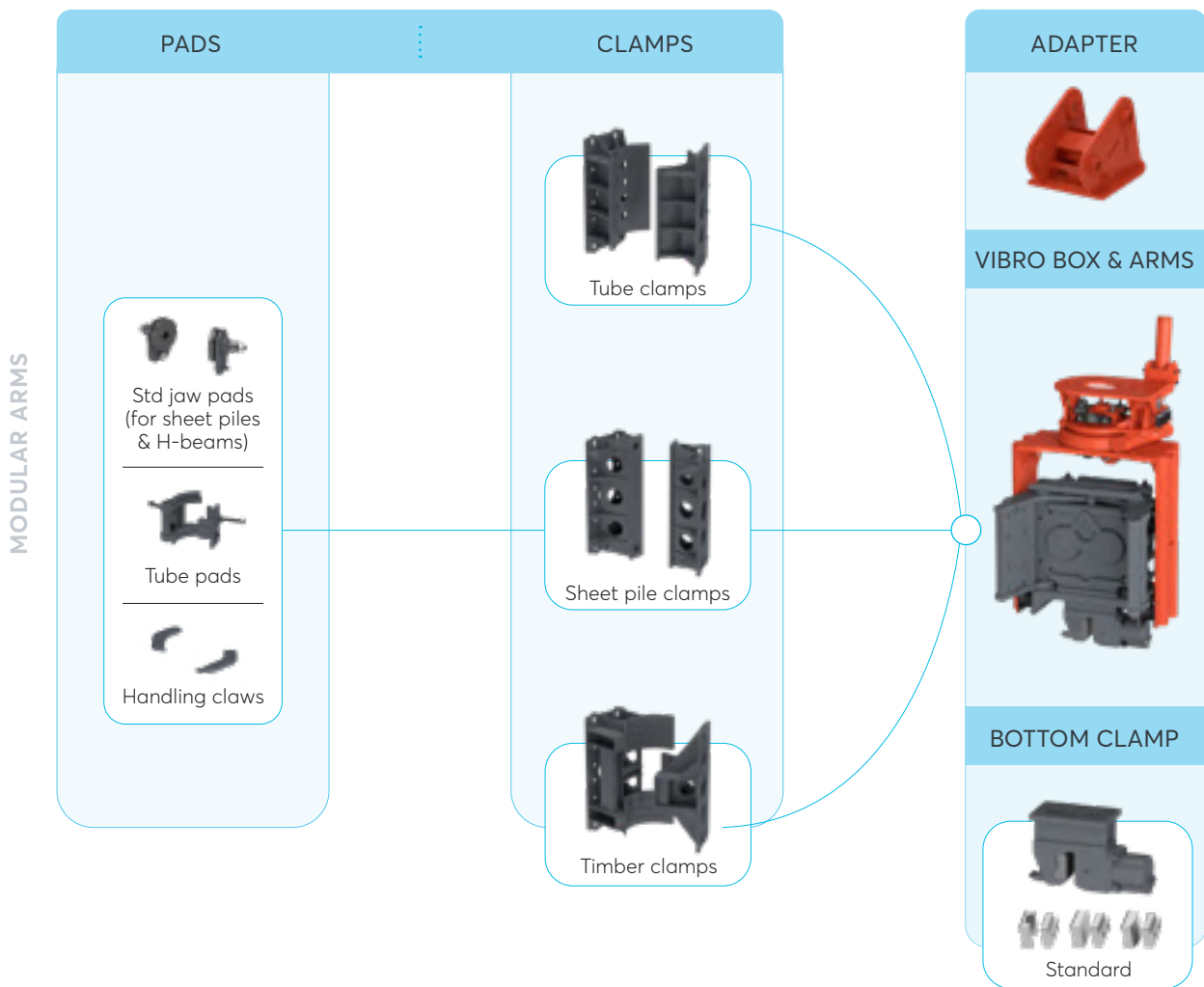

# SIDE GRIP VIBRATORY PILE DRIVERS

## MOVAX MODULAR SYSTEM

Fixed eccentric (LITE)

### MODULAR ARMS

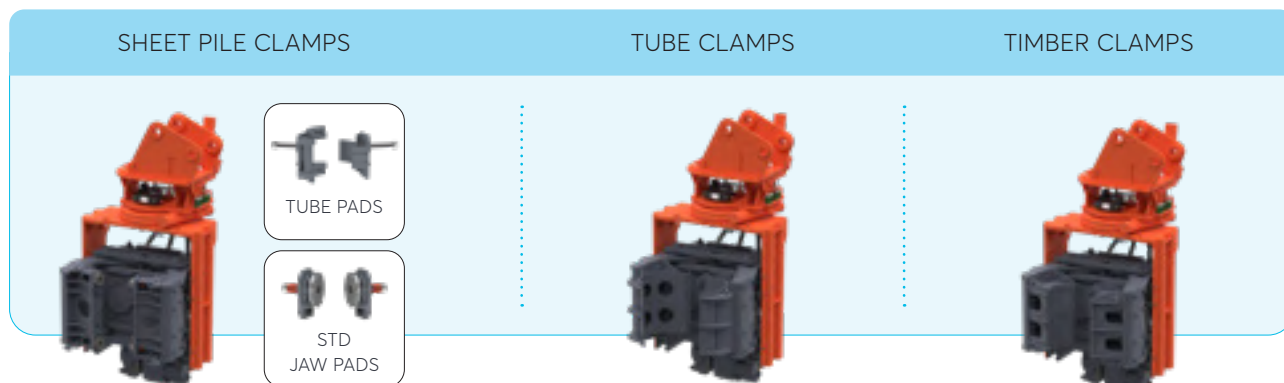

# SIDE GRIP VIBRATORY PILE DRIVERS

## MODULAR ARMS

### Fixed eccentric (LITE)

Modular arms are suitable for driving sheet piles, H-beams, tubular steel piles and timber piles.

Sheet pile clamps are utilised to drive sheet piles and H-beams. The sheet pile clamps can be equipped with tube pads for tubular steel piles up to OD 273 mm. Each tube size requires its own tube pads of matching size in order to ensure proper operation.

Tube clamps are utilised for larger tubular steel piles. Each tube size requires also its own tube clamps.

Timber clamps are utilised to drive timber or wooden piles. A range of round timber piles can be driven with the same timber clamps whereas square timber piles requires clamps of the same size.



# SIDE GRIP VIBRATORY PILE DRIVERS

## MODULAR ARMS

### Fixed eccentric (LITE)



#### TUBE CLAMPS

for tubular steel piles from  
OD 88.9 mm up to  
OD 323.9/508 mm:

#### SG-30N...SG-40N

Ø 88.9–508 mm

#### SG-15N

Ø 88.9–323.9 mm

#### Standard sizes

Ø 88.9	Ø 168.3
Ø 101.6	Ø 219.1
Ø 114.3	Ø 273
Ø 127	Ø 323.9
Ø 139.7	Ø 406.4
Ø 457	Ø 508



#### SHEET PILE CLAMPS

for sheet piles and H-beams and tubular  
steel piles from OD 88.9 mm to OD 273 mm:

#### SHEET PILE PADS

#### SG-30N...SG-40N

w 400–1200 mm/H120-H400

#### SG-15N

w 400–600 mm/H120-H140

#### TUBE PADS

#### Standard sizes

Ø 88.9	Ø 139.7
Ø 101.6	Ø 168.3
Ø 114.3	Ø 219.1
Ø 127	Ø 273



#### HANDLING CLAWS

Available for SG-30N & SG-40N.

Available as optional add-on for the SG-15N  
(not included with the base unit).



#### TIMBER CLAMPS

for timber piles from  
OD 100/120 mm up to  
OD 300/325 mm:

A range of round timber pile  
sizes can be driven with the  
same timber clamps.

#### Standard sizes

#### SG-30N & SG-40N

S Ø 140-250 mm

M Ø 220-325 mm

#### SG-15N

S Ø 100-200 mm

M Ø 200-300 mm

In addition clamps for  
square timber piles are also  
available.

Each square timber pile  
size requires clamps of  
matching size.

Customised sizes are available by request. (e.g. clamps for square timber piles or other special profiles).

MODULAR ARMS are designed for versatility and to handle, pitch, drive and extract sheet piles, tube piles or timber piles.



Handling, pitching,  
driving & extracting  
tube piles



Handling, pitching,  
driving & extracting  
sheet piles



Handling, pitching,  
driving & extracting  
small OD tube piles



Handling, pitching,  
driving & extracting  
timber piles



# SIDE GRIP VIBRATORY PILE DRIVERS

## BOTTOM CLAMP incl. OPTIONS

### Fixed eccentric (LITE)

The (standard) bottom clamp is utilised for the completion of the pile driving and is suitable for all kinds of piles including sheet piles, H-beams and tubular steel piles, as well as timber piles.

The bottom clamp is equipped with pads for the specific pile type in question, Sheet pile pads are utilised for sheet piles and H-beams, Double (sheet) pile pads are recommended when driving double sheet piles (both U and Z). Tube pads are available from OD 323,9 mm to 508 mm; covering the entire size range as specified.

Smaller OD tube piles and timber piles require a top hitter. The same top hitter is suitable for the entire range.



Sheet pile pads



Tube pads\*  
OD 323,9...508 mm



Double (sheet)  
pile pads\*  
Available for double-Z  
type sheet piles

#### Top hitter (optional)

Smaller OD tube piles (from 88,9 mm to 323,9 mm and timber piles require a top hitter. The same top hitter is suitable for the entire range.

Top hitters for larger OD piles and f. ex. square timber piles are available by request.



#### Lifting lever (SG-30N, SG-40N only)

The bottom clamp is equipped with a lifting lever for handling of sheet piles.

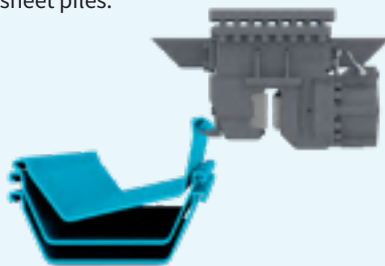

\* Available for SG-30N & SG-40N.

# SIDE GRIP VIBRATORY PILE DRIVERS

## TECHNICAL DATA

### Fixed eccentric (LITE)

Model		SG-40N	SG-30N	SG-15N
Weight	kg	1505	1485	760
Height	mm	2042	2042	1500
Depth	mm	1138	1138	900
Width	mm	1030	1030	850
Frequency	1/min	2300-3000		
Eccentric moment	kgm	4,1	3,1	1,6
Centrifugal force, max	kN	400	300	150
Ground vibration		normal		
Resonance-free start/stop		no		
Driving method		vibration		
Swing/tilt angle	°	360/30		
Return pressure, max	bar	5		
Pressure setting	bar	350		300
Excavator class	t	17-21	13-16	7-12
Engine power, min. TIER III	kW	85	65	38
Engine power, min. TIER IV	kW	90	70	38

### Suitable piles

Length & weight	m/kg	6 / 400 8 / 1000 10 / 900	4 / 400 6 / 200	
Sheet piles, width	mm	400 - 1200	400 - 600	
Sheet piles, max. depth	mm	260	140	
Trench sheets	size	330-600		
H-beams	size	H100-H400	H100-140	
Timber piles	mm	Ø140-325	Ø100-300	
Tubular steel piles, tubes	mm	Ø88,9-508	Ø88,9-323,9	



# SIDE GRIP VIBRATORY DRIVER, LEADER-GUIDED

## MOVAX MODULAR SYSTEM

### Fixed eccentric (SGL)

MOVAX SGL is an excavator mounted leader guided side grip vibratory pile driver designed to meet the high-quality requirements of the installation of the mounting systems for utility scale photovoltaic solar power plants.

The MOVAX Modular System (MMS™) enables easy and efficient changing of clamps and pads - and thus the use of the same MOVAX side grip pile driver for a wide range of different piles and profiles.



# SIDE GRIP VIBRATORY DRIVER, LEADER-GUIDED

## MODULAR ARMS

### Fixed eccentric (SGL)

MOVAX SGL-models are always equipped with modular arms that can be fitted with either multi-purpose or tube clamps.

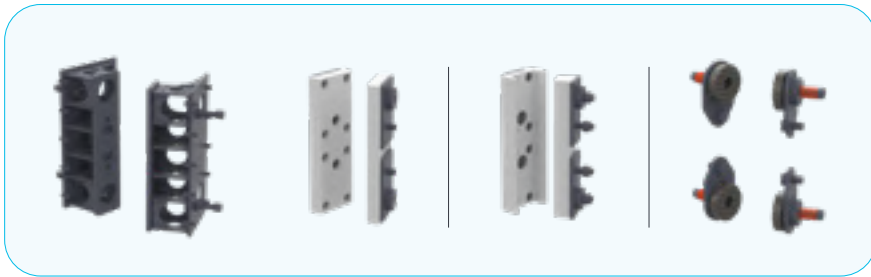

#### Multi-purpose clamps

Clamps are available for a wide range of piles and profiles: sheet piles, tubular steel piles (max. 250 diameter), H-beams, sigma- and C- profiles.



#### Tube clamps

Tube clamps are utilised for driving tubular steel piles.



# SIDE GRIP VIBRATORY DRIVER, LEADER-GUIDED

## TECHNICAL DATA

### Fixed eccentric (SGL)

Model	SGL-15N	
Weight	kg	1390-1505
Height	mm	3505
Depth	mm	1480
Width	mm	1125
Vertical stroke	mm	1500
Frequency	1/min	2300 - 3000
Eccentric moment	kgm	1,6
Centrifugal force, max	kN	150
Ground vibration		normal
Resonance-free start/stop		no
Driving method		vibration
Swing/tilt angle	°	200/30
Return pressure, max	bar	5
Pressure setting	bar	300
Excavator class	t	13-21
Engine power, min., TIER III	kW	38
Engine power, min., TIER IV	kW	38

### Suitable piles

Length & weight	m x kg	9 / 400
C-, U- & Sigma profiles	width	100 - 300 mm
	depth	40 - 140 mm
H-beams	size	H120-H140
Timber piles	size	Ø100-200 mm
		Ø200-300 mm
Tubular steel piles, tubes	size	Ø88,9-323,9 mm







## INTRODUCTION

# PILING HAMMER TECHNOLOGY

MOVAX Piling Hammers are hydraulic, double acting impact-type, piling hammers utilised for driving load-bearing piles or assisting in sheet pile driving in even the most difficult soil conditions.

MOVAX piling hammers can be utilised to complete a pile installation after reaching refusal with a side grip pile driver or when load testing is required. MOVAX piling hammers can further be utilised independently for driving a wide range of piles including sheet piles, H-beams, tubular steel piles, timber piles or pre-cast concrete piles.

MOVAX piling hammers are excavator mounted – either directly mounted onto the excavator, or in connection with an excavator mounted piling leader. As the MOVAX piling hammers utilize the hydraulic power of the excavator as its driving force no external sources of energy such as power packs are needed.

### Hydraulic, double-acting piling hammer

MOVAX hydraulic piling hammers uses the hydraulic energy produced by the excavator to lift the ram of the piling hammer to the desired elevation. When the piling hammer is released from its desired drop height the potential energy is then translated into the corresponding kinetic energy. This kinetic energy is utilized to drive the pile. External energy is added to the potential energy with the hydraulics of the excavator in order to overcome friction etc losses. Hence the definition 'double-acting'.

The working cycle is as follows: lift ram, release/ drop ram, re-lift ram, and so on. Both the drop height and the blow count can be flexibly adjusted based on the pile and piling requirements thus precisely controlling the energy utilized (as required) for the pile driving.

The ram velocity prior to impact is measured and the operator can monitor the impact energy with the MOVAX control system.

The efficiency of the MOVAX piling hammer is high, > 95%.

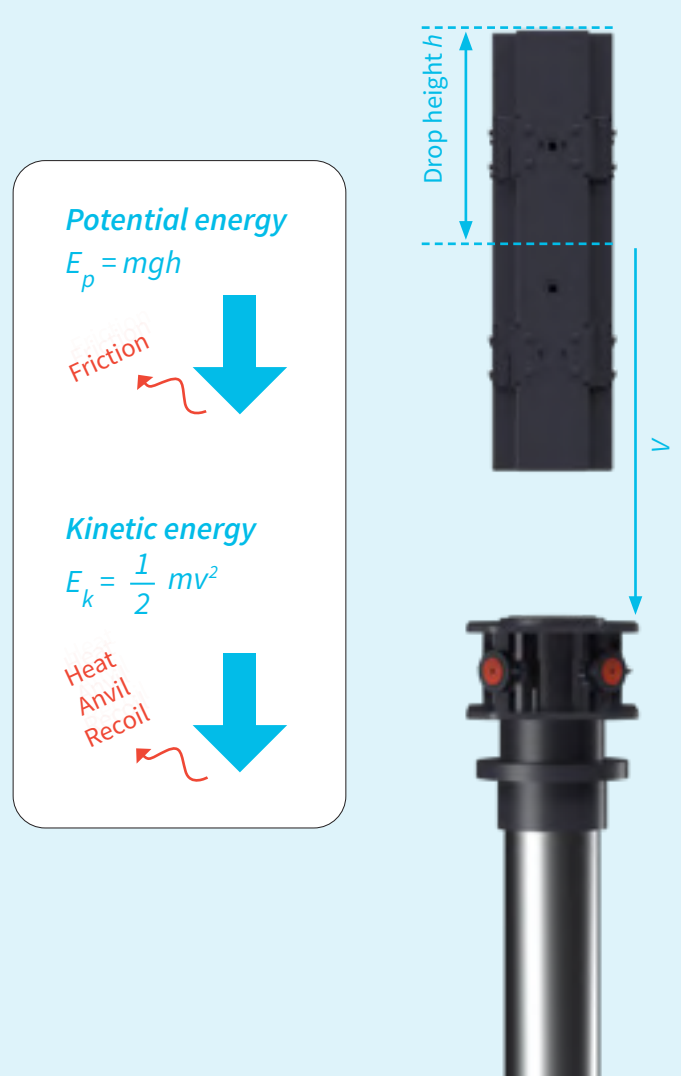



# PILING HAMMERS

## FEATURES



### EXCAVATOR-MOUNTED

- Suitable for 20-50 ton excavators.
- Utilizing the hydraulic power and lifting capacity of the excavator or rail roader (carrier).
- Designed to work on any and all wheeled and crawler-type excavators and rail roaders by utilising and commanding the standard auxiliary hydraulics and/or by connecting to the electronic control of the excavator.

### COMPREHENSIVE MODEL & SIZE RANGE

- Available in different models, sizes and configurations for different piling requirements and different type of piles ranging sheet piles and H-beams to tubular steel piles, precast concrete piles and timber piles.
- Available for excavators ranging from 20 to 50 ton – thus always ensuring the optimum size and correct combination of piling hammer and excavator.

### DOUBLE ACTING, IMPACT TYPE TECHNOLOGY

- Drop height controlled between 0-1,2 m
- Blow count controlled between 1-100 blows per minute

### VERSATILE OPTIONS

- Tilt device with +/- 15° tilt.
- Bolt-on plate mounted tilt (+/- 15°) & rotation device (+/- 60°) for optimum sheet pile driving  
(note! models DH-15 and DH-25, only).
- Available with 2,5 ton capacity pile handler for handling of different type of piles. Pile handler can be retrofitted on an existing MOVAX piling hammer.
- The same MOVAX piling hammer can be used on different carriers; mounting options include excavator-, MOVAX multi-tool piling leader-, (third party) piling rig- or crane.

### MOVAX MODULAR SYSTEM

- Versatility based on the MOVAX Modular System™ which enables the use of the same unit for a wide range of different piling requirements and type of piles. The modular system includes a wide range of pile caps.

### MOVAX CONTROL SYSTEM

- MOVAX Control System, mControl+
  - mControl+ LITE
  - mControl+ PRO with automatic tip-control for maximised productivity and quality.

### MOVAX INFORMATION MANAGEMENT SYSTEM

- mFleetManagement for monitoring MOVAX piling equipment operation, performance and condition.
- Optional mLogbook for monitoring and reporting the piling works including pile set criterion.

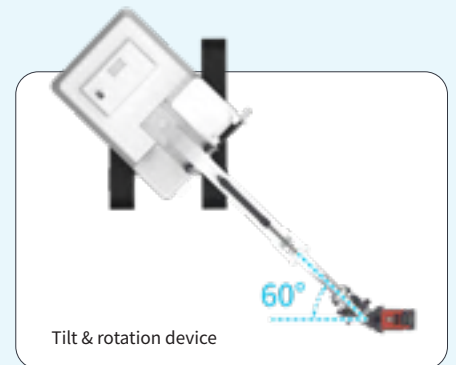

### DRIVING LOAD BEARING PILES & ASSISTING IN SHEET PILE DRIVING



## PILING HAMMERS

# MOUNTING OPTIONS

The MOVAX piling hammers can be mounted directly onto the excavator (stick), onto MOVAX Multi-tool piling leader, or a third-party piling rig or crane.



Excavator-mounted



MOVAX multi-tool piling leader-mounted



Piling rig-mounted



Crane-mounted

Due to the modular design the same MOVAX piling hammer can be used on all the various carriers with minimum modifications. The mounting bracket, top cover and lower frame must be selected in accordance with the mounting option.

### MOUNTING BRACKET

Each mounting option requires its own mounting bracket (except crane-mounting which do not require a mounting bracket).



Excavator-mounted



MPL-mounted



Piling rig-mounted

### TOP COVER

The top cover is the same for the excavator- and multi-tool piling leader (MPL)- mounted DH piling hammer. When mounting the DH on a third party piling rig or on a crane a top cover with lifting lugs is required.



Excavator- & MPL-mounted



Piling rig-/crane-mounted

### LOWER FRAME

The lower frame is the same for the excavator-, multi-tool piling leader (MPL)- and piling rig-mounted DH piling hammer. The crane-mounted piling hammer is equipped with a pile sleeve ("bell") with pile guides available separately for tubular steel piles and sheet piles.



Excavator-, MPL- & piling rig-mounted



Crane mounted (with Bell)



# PILING HAMMERS

## PILE HANDLER

The MOVAX DH piling hammers can be equipped with a pile handler for added pile handling capabilities. The pile handler can also be added to existing MOVAX DH piling hammers by simply changing the top cover and adding the pile handler winch and guide.



### TECHNICAL DATA

Technical data		
Lifting capacity	kg	2500
Wire rope length	m	36
Total weight	kg	160





# PILING HAMMERS

## SELECTION

The suitable MOVAX piling hammer-model is selected based on the soil & site conditions, the excavator and the main dimensions (weight & length) of the piles to be driven. The configuration is then defined by the type of piles.

### Excavator (carrier)

The excavator must be suitable – and match – the specific piling hammer in question in regards to hydraulic power (oil flow @ pressure) and have the sufficient handling capacity for stable operation. Thus the excavator brand & model is needed for the correct selection of model.

### Mounting options

The same MOVAX piling hammer can be used on different carriers; mounting options include excavator-, MOVAX multi-tool piling leader-, (third party) piling rig- or crane. For the suitability of mounting onto MOVAX multi-tool piling leaders refer to the Product Catalogue section in question. The suitability of a MOVAX piling hammer for third party piling rig or crane installation shall always be checked by MOVAX.

### Site and soil conditions

Piling hammers are suitable for a wide range of sites and soil conditions (N-values/SPT). In order to make a detailed analysis of the suitability of a MOVAX model for a specific project a soil report is needed.

### Type & dimension of piles

In order to select the correct MOVAX model, the type of piles (sheet pile, H-beam, tubular steel pile, precast concrete and/or timber pile) and their dimensions (length, width/depth, OD) are needed. Due to the modular design the same MOVAX piling hammer can be used to drive different type of piles.

## SELECTION CHART

EXCAVATOR CLASS	(38) 40-50 ton	(33) 35-50 ton	(28) 30-50 ton	(20) 23-50 ton
<b>PILE SIZE</b> (length/weight)				
Max. pile length and weight based on excavator reach and stability.	<b>DH-45</b>	<b>DH-35</b>	<b>DH-25</b>	<b>DH-15</b>
<b>SUITABLE PILES</b>				
Sheet piles	width 400-700 mm			
H-beams	H180-H700		H180-H500	
Precast concrete piles (max)	508 mm x 508 mm			
Timber piles	Ø 90-510 mm			
Tube piles	Ø 88.9-1200 mm		Ø 88.9-762 mm	

NOTE!

Preliminary. When making the final selection the excavator engine size and hydraulic system design (oil pump arrangement, oil flow rate/pressure etc), excavator lifting capacity and stability and soil and site conditions shall be taken into account.

# PILING HAMMERS

## PILE CAPS

MOVAX piling hammers can be equipped with the following standard type of pile caps (customized pile caps are available upon request):

### SHEET PILES / H BEAMS



**S** for PU and GU sheet piles 600 mm / H-beam < 500 mm



**M** for AU sheet piles > 700 mm / H-beams < 700 mm

### TUBULAR STEEL PILES, MICROPILES



**DH-15 and DH-25**  
XS Ø 88,9–273 mm



**DH-35 and DH-45**  
XS Ø 88,9–323,9 mm

### TUBULAR STEEL PILES

Tubular steel pile caps are supplied with an external guide (as a standard, unless otherwise requested).

Flat type pile cap and pile cap with internal guide are available by request.

S Ø 273-508 mm  
M Ø 406,4-762 mm  
L Ø 762-1220 mm



External guide (Standard)

Available by request:



Flat



Internal guide

### PRE-CAST CONCRETE PILES



XS 225 x 225 mm    L 350 x 350 mm  
S 250 x 250 mm    XL 450 x 450 mm  
M 300 x 300 mm

Customised, pile caps are available from 180 x 180 mm to 508 x 508 mm.

### TIMBER PILES



**DH-15, DH-25**

**Round**

XS Ø 90–220  
S Ø 220–510

**Square**

XS 225 x 225 mm  
S 250 x 250 mm  
M 300 x 300 mm  
L 350 x 350 mm



**DH-35, DH-45**

**Round**

XS Ø 90–325  
S Ø 270–510

**Square**

XS 225 x 225 mm  
S 250 x 250 mm  
M 300 x 300 mm  
L 350 x 350 mm

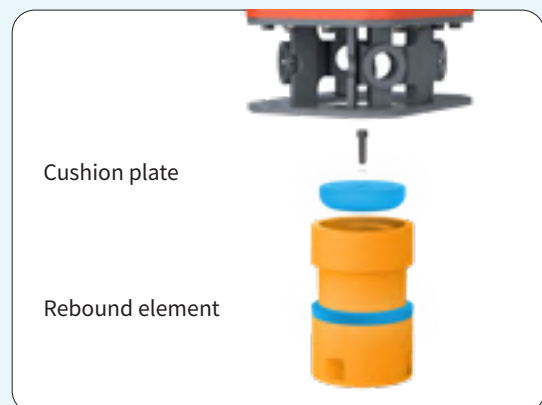

NOTE! A single pile cap can handle the given range.

# PILING HAMMERS

## TECHNICAL DATA

Model		DH-45	DH-35	DH-25 <sup>4</sup>	DH-15 <sup>4</sup>
Total weight <sup>1</sup>	kg	6700	5750	4400 <sup>2</sup> /4700 <sup>3</sup>	3500 <sup>2</sup> /3800 <sup>3</sup>
Ram weight	kg	4000	3100	2060	1360
Blows per minute	1/min	0-100	0-100	0-100	0-100
Impact energy	kNm	0-45	0-35	0-25	0-15
Drop height	m	0-1,2	0-1,2	0-1,2	0-1,2
Pressure relief set, max.	bar	350	350	350	350
Operating pressure	bar	280	250	200-250	150
Oil flow rate	l/min	80-120	80-120	80-120	80-120
Tilt angle	°	+/-15	+/-15	+/- 15	+/-15
Rotation angle	°	N/A	N/A	+/-60	+/-60
Leader	m	1,3	1,3	1,3	0,7
Leader, type		floating	floating	floating	floating
Total height	mm	4930	4460	4460	3850
Frame width	mm	650	650	500	500
Transport width	mm	1200	1200	1200	1200
Transport depth	mm	1870	1870	1870	1870
Excavator class	t	(38)-50	(33)-50	(28-33)-50	(20)-50

<sup>1</sup> excluding adapter

<sup>2</sup> with tilt

<sup>3</sup> with tilt+rotate

<sup>4</sup> performance data without extensions



### MODULAR DESIGN (DH-15 & DH-25)

The MOVAX DH-25 is designed so that a modular ram/frame extension assembly can be added enabling the use of the same DH-25 piling hammer with a ram weight of 3 tons.

The MOVAX DH-15 is designed so that the ram/frame can be changed enabling the use of the same DH-15 with a ram weight of 2 tons.





## INTRODUCTION

# PRE-AUGERING TECHNOLOGY

Pre-augering is utilised to soften the ground allowing vibratory pile driving and impact pile driving in harder soil conditions.

Pre-augering is most typically associated with sheet piling driving in dense soils where pre-augering the sheet pile line is in many cases advisable. Pre-augering helps in reducing the density of the ground and thus assisting in the sheet pile driving.

Pre-augering also enables easier extraction of for instance sheet piles, especially when the piles have been in the ground for an extensive period of time.

When pre-augering the auger flights are rotated into the ground in one direction and then counter-rotated out of the ground leaving the soil in-place.

Benefits of pre-augering includes increased productivity and quality and also reduced noise and disturbances to the surroundings (potentially caused by vibration).

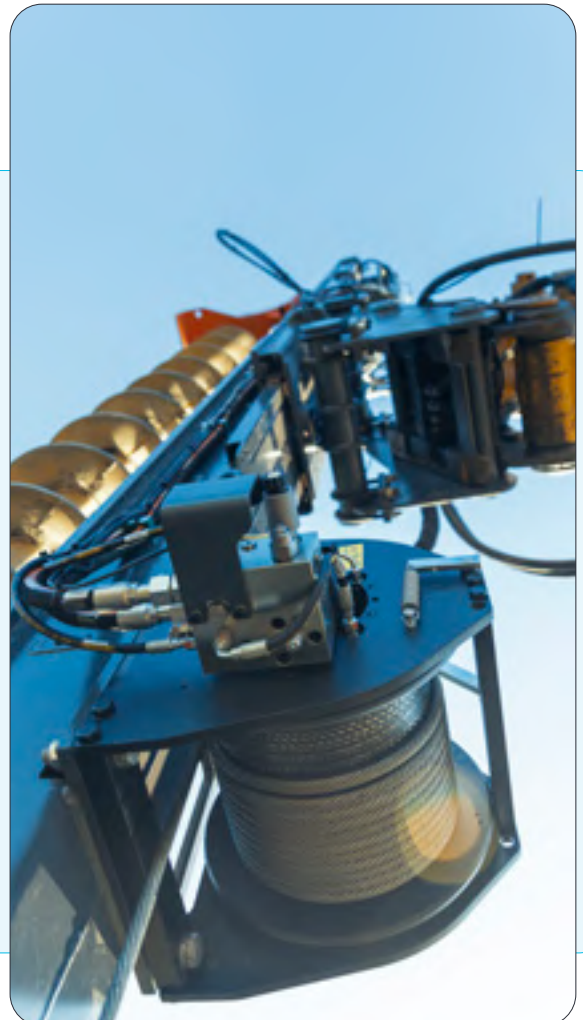



# PRE-AUGERS

## FEATURES

### EXCAVATOR-MOUNTED

- Utilizing the hydraulic power and lifting capacity of the excavator or rail roader (carrier).
- Vertical movement of the auger drive is realized with two hydraulic winch drives to enable small bore holes where soil softening is required

### MODULAR DESIGN

- Due to modular design, the leader is available for 9 m and 12 m effective augering depths
- Equipped with auger selected in accordance with soil conditions

### STATE-OF-THE-ART CONTROL

- Controlled with the MOVAX Control System (mControl+™)

## SELECTION

The suitable MOVAX pre-auger is selected based on the soil & site conditions and the excavator to be utilized as carrier. The pre-auger is either stick or boom mounted; the selection is made based on the excavator to be used as carrier.

The lead auger and auger sections are selected based on the ground conditions and the desired diameter (typically the auger diameter is the same as the width of the pile).

EXCAVATOR CLASS	33-50 t	28-32 t	23-28 t	20-24 t	17-21 t	13-16 t	7-11 t
MOVAX PA-50	STICK-MOUNTED		BOOM-MOUNTED				
PILE SIZE DRIVEN WITH THE SG (length x weight)							
6 m x 2800 kg 12 m x 1900 kg 16 m x 1300 kg	<b>SG-80VA</b> <b>SG-75V</b> <b>SG-75</b>						
8 m x 2300 kg 12 m x 1800 kg 16 m x 1200 kg		<b>SG-65VA</b> <b>SG-60V</b> <b>SG-60</b>	<b>SG-50VA</b> <b>SG-50V</b> <b>SG-50</b>	<b>SG-45VA</b> <b>SG-45V</b> <b>SG-45</b>			
6 m x 1200 kg 12 m x 1000 kg 16 m x 900 kg					<b>SG-40N</b> <b>SGL-15N</b>	<b>SG-30N</b> <b>SGL-15N</b>	
4 m x 400 kg 6 m x 200 kg							<b>SG-15N</b>

The Selection Chart provides the preliminary selection; When making the final selection the excavator engine size and hydraulic system design (oil pump arrangement, oil flow rate/pressure etc.), excavator lifting capacity and stability and soil and site conditions shall be taken into account.

## PRE-AUGERS

# TECHNICAL DATA



Model	PA-50	
Weight (w/o adapter and auger)	kg	3200
Height	m	14,7
Forward inclination	°	5
Backward inclination	°	10
Tilt	°	±4
Winches		
Main winch	kN	57
Crowd winch	kN	57
Crowd system		
Max. pull down force	kN	57
Max. extraction force	kN	57
Effective depth	m	9/12
Hole diameter	mm	max. 600
Excavator class	t	25-35

*note! the PA-50 pre-auger is a stand-alone product and it is designed for pre-augering only*



Model	Hydra T-5000	
Total weight	kg	600
Torque, max.	kNm	50
Drilling speed	rpm	0-40
Connecting pin, hexagonal	mm	70
Oil flow	l/min	240
Maximum pressure	bar	350
Drilling depth	m	12

## INTRODUCTION

# PILING DRILL TECHNOLOGY

MOVAX Piling drills are excavator-mounted, telescopic/kelly bar-type auger drive attachments for cast-in-situ (concrete) piling and other soil removal tasks.

MOVAX Piling drills are explicitly designed for soil removal tasks. MOVAX piling drills are especially suitable for work in confined spaces while still being good at reaching over obstacles. The telescopic/kelly bar design keeps the drill height low and allows working on sites with limited headroom without compromising on drilling depth.

MOVAX piling drills are operated by transferring the torque and crowd force from a rotary drive tool to the drilling tool. **MOVAX utilises two different designs: a telescopic design (TAD-models) and a kelly bar design (KB-models).**

### KELLY BAR PILING DRILL TECHNOLOGY

MOVAX kelly bar-design piling drills utilize interlocking-type kelly bars which have drive ribs welded with lock devices utilized to transfer the maximum amount of torque to each section. The standard kelly bars are manufactured as a fully lockable system with a mechanical locking mechanism between each element, the outer bar and the rotary drive.

The kelly-bar design piling drill can also be used for cased drilling

### TELESCOPIC PILING DRILL TECHNOLOGY

MOVAX telescopic-design piling drills are cylinder/chain driven. The piling drills consists of one or two moving sections.







# PILING DRILLS

## FEATURES

### EXCAVATOR-MOUNTED

- Suitable for 20-50 ton excavators.
- Utilizing the hydraulic power and lifting capacity of the excavator or rail roader
- Designed to work on any and all wheeled and crawler-type excavators and rail roaders by utilising and commanding the standard auxiliary hydraulics and/or by connecting to the electronic control of the excavator.

### TELESCOPIC

- Light weight, telescopic type piling drills with a maximum drilling depth of 9 meters intended primarily for basic rail roaders and smaller excavators.

### KELLY BAR

- Heavy duty, kelly bar type piling drills with a maximum drilling depth of 20 meters intended primarily for heavy duty rail roaders and large excavators.

### MOVAX MODULAR SYSTEM

- Versatility based on the MOVAX Modular System™ which enables the use of the same unit for a wide range of different piling requirements.
- The modular system includes a wide range of lead augers in different sizes and for different soil conditions.
- Service winch (optional, KB-models only)
- Casing adapter and cardan joint for cased drilling

### MOVAX CONTROL SYSTEM

- mControl+ LITE
- mControl+ PRO

#### LEAD AUGERS



Heavy duty/conical



Rock/cylindrical



TELESCOPIC PILING DRILL (TAD)

#### SERVICE WINCH



#### CASED DRILLING



Cardan joint



Casing adapter



KELLY-BAR TYPE PILING DRILL (KB)

## CAST-IN SITU CONCRETE PILING & SOIL REMOVAL



## PILING DRILLS

# TECHNICAL DATA

### Models KB (kelly bar)

Model		KB-70L	KB-70S
Drilling depth*	m	20-25	9-15
Weight**	kg	6000-6500	5000-5400
Height**	mm	6550	5850
Oil flow rate	l/min	100-200	100-200
Oil pressure	bar	350	350
Hole diameter	mm	420-1500	420-1500
Drill speed range	rpm	10-120	10-120
Side tilt angle	°	±15	±15
Torque	kNm	70	70
Extraction force	kN	75	75
Crowd force	kN	190	190
Excavator class***	t	35-50	(30) 35-50

#### Lead augers

Model		rock or heavy duty
Outer diameter	mm	420-1500

#### Accessories (optional)

Service winch	2,5 ton for handling rebar or reinforcement steel
Casing adapter	tailor-made according to customer specifications
Cardan joint	tailor-made according to customer specifications

\* drilling depth dependent on length of kelly bar

\*\* excluding adapter and lead auger

\*\*\* stick or boom mounted; excavator suitability to be checked



## PILING DRILLS

# TECHNICAL DATA

### Models TAD (telescopic)

Model		TAD-32	TAD-51
Drilling depth	m	9	6
Weight*	kg	3200	3200
Height*	mm	3855	3855
Oil flow rate	l/min	75-250	75-250
Oil pressure	bar	350	350
Hole diameter	mm	400-1000	400-1000
Drill speed range	rpm	11-74	11-74
Side tilt angle	°	±30	±30
Torque	kNm	30	50
Extraction force	kN	30	60
Crowd force	kN	15	15
Excavator class**	t	24-35	24-35

#### Lead augers

Model		rock or heavy duty
Outer diameter	mm	400-1000

\*excluding adapter and lead auger

\*\*stick or boom mounted; excavator suitability to be checked





# INTRODUCTION

## MANIPULATORS

MOVAX excavator mounted manipulators are designed for fast, flexible and efficient handling of different kinds of masts, gantries, and poles as well as a wide range of piles. Based on the patented side grip technology, the MOVAX manipulator is designed for superior maneuverability, safety and accuracy.

### Manipulator technology

The manipulator has a rotary gear for a full 360 degree continuous tilt and cylinders for a +/- 60° rotation providing unlimited and precise handling and positioning of profiles.

The manipulator is capable of handling different type of profiles ranging from double-U-, U-, H-, and I- to rectangular and tubular-shapes as well as sheet piles, tubular steel piles, timber piles and precast concrete piles. Soft gripping surfaces are available if required to efficiently prevent damaging sensitive surfaces of masts, gantries or poles.

MOVAX Manipulators are controlled with the **MOVAX Control System** for precision and accuracy, efficiency and safety:

- Easy and exact positioning with integrated inclination sensor and mControl+ (control system) display
- Smooth movements with thumb wheel operated proportional control
- Clamping pressure shown on screen
- Integrated safety lock valves on cylinders
- Safety switch for clamp opening
- Adjustable gripping force



# MANIPULATORS

## FEATURES

### EXCAVATOR-MOUNTED

- Suitable for 20-50 ton excavators.
- Utilizing the hydraulic power and lifting capacity of the excavator or rail roader
- Designed to work on any and all wheeled and crawler-type excavators and rail roaders by utilising and commanding the standard auxiliary hydraulics and/or by connecting to the electronic control of the excavator.

### MOVAX MODULAR SYSTEM

- Available for masts, poles gantries and different type of piles including sheet piles, tubular steel piles and precast concrete piles.
- Available with gripping surfaces tailor-made for the profiles to be handled; for example to prevent scratching, etc.

### MOVAX CONTROL SYSTEM

- Operated and monitored with the MOVAX Control System, mControl+ LITE/PRO for precision and accuracy.
- Integrated safety systems.
- Adjustable gripping force for galvanised poles and other sensitive profiles.

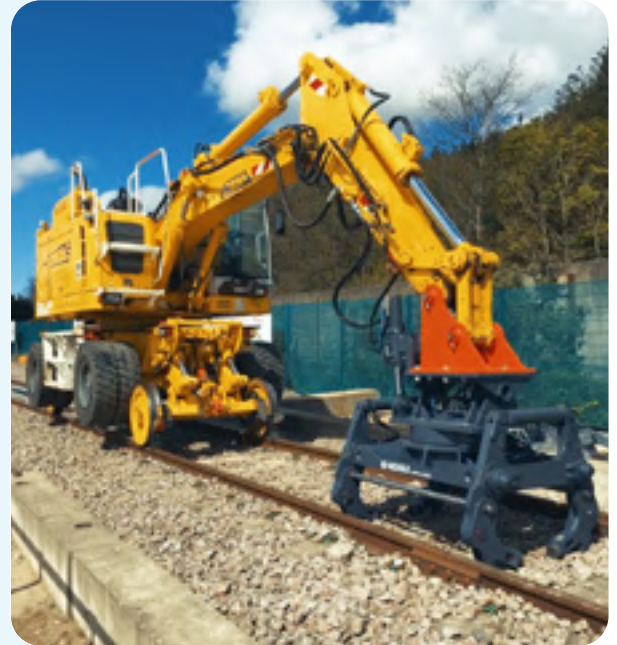

# MANIPULATORS

## MOVAX MODULAR SYSTEM

The MOVAX Modular System enables the use of the same Manipulator for the handling of a wide range of different type of profiles ranging from double-U-, U-, H-, and I- to rectangular- and tubular-shapes as well as sheet piles, tubular steel piles, timber piles and precast concrete piles. Gripping surfaces are available for different type of materials and surfaces.

Standard MOVAX Manipulator clamps are available for sheet piles, tubes and square sections. Also customised clamps are available upon request.

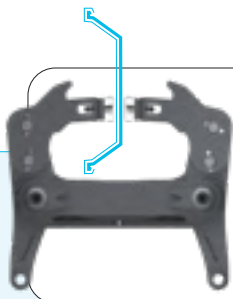

### SHEET PILE CLAMPS

For sheet piles, H-beams and similar  
W400–1600 mm, H100–1000 mm.



### TUBE CLAMPS

For tubular steel pipes OD 88.9–1220 mm.



### CUSTOM CLAMPS

For round, square, hexagonal, etc. OD up to 1220 mm.  
Also for conical shapes.

With soft gripping surfaces to protect the surface coating.





# MANIPULATORS

## TECHNICAL DATA

Technical data		MPM-10
Weight (excl. adapter)	kg	4150
Height	mm	2666
Depth*	mm	1872
Width*	mm	1810
Rotation angle	°	360
Tilting angle	°	+/- 30
Relief valve pressure, max.	bar	350
Excavator class	t	40-55

Suitable piles		
Length/weight	m/kg	12 m/6000 kg 16 m/5300 kg 20 m/4700 kg
H-beams	size	H180-H1000
Tubular piles, tubes	size	Ø88,9-1300 mm
Sheet piles, max. depth	size	265 mm
Timber piles	size	Ø160-420 mm

*\*the exact dimensions depend on the selected clamp type*

Technical data		MPM-4
Weight (excl. adapter)	kg	1550 - 1750
Height	mm	1562
Depth*	mm	1700 - 2300
Width*	mm	960 - 1400
Rotation angle	°	+/-60
Tilting angle	°	360
Relief valve pressure max	bar	350
Excavator class	t	18-35

Suitable piles		
Length/weight	m/kg	6m/4000kg 12m/1000kg
Square sections & H-beams	size	H100-H1000 100x100 up to 650x650
Tubular piles, tubes	size	Ø88,9-1220 mm
Sheet piles, max. depth	size	265 mm
Timber piles	size	Ø160-420 mm

*\*the exact dimensions depend on the selected clamp type*

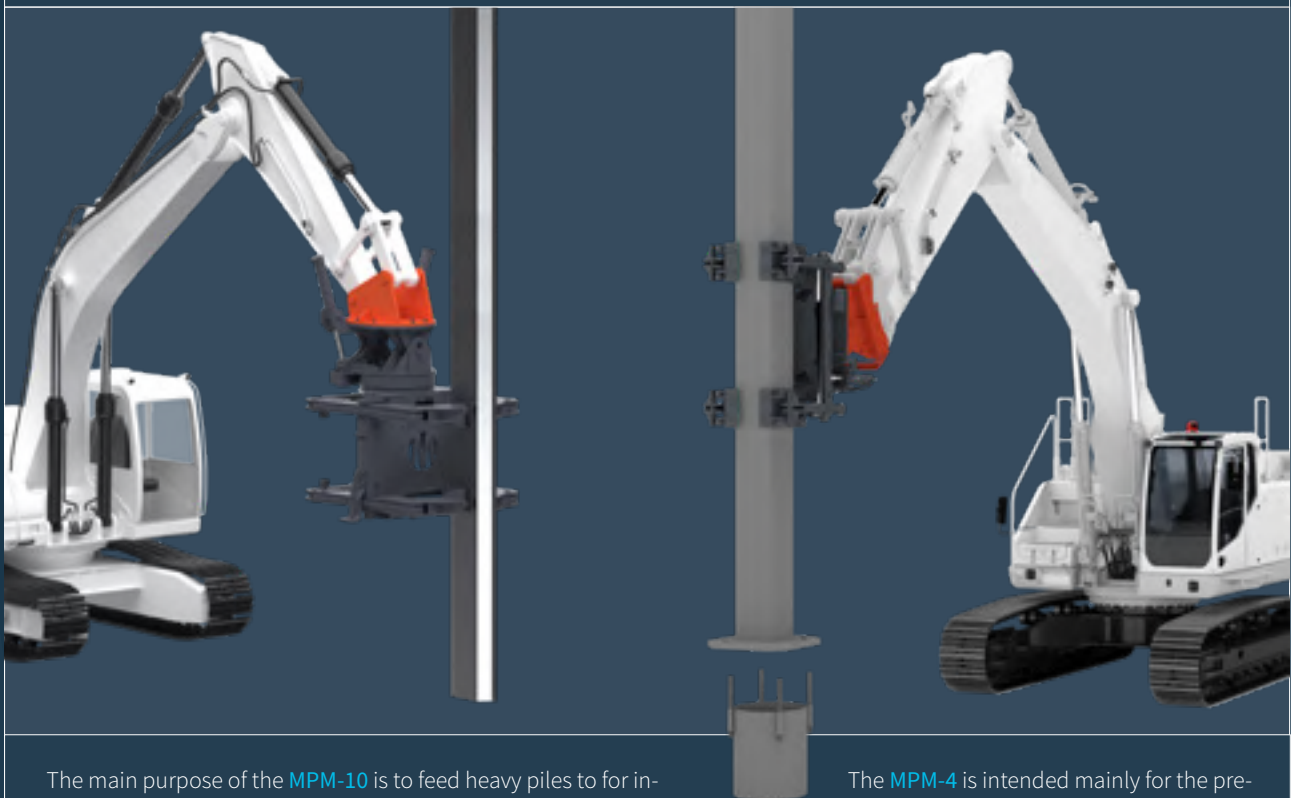

The main purpose of the **MPM-10** is to feed heavy piles to for instance piling rigs, silent pilers etc. The MPM-10 can also be utilised for the precise manipulation of a wide range of different profiles.

The **MPM-4** is intended mainly for the precise handling and positioning ('manipulation') of different type and shape profiles.

# INTRODUCTION

## MULTI-TOOL PILING LEADERS

**MOVAX MPL multi-tool piling leaders** provide an excavator mounted, versatile, multi-tool solution for a wide range of piling requirements in a variety of site and soil conditions, and for different types of piles and piling technologies ranging from driven (vibratory & impact hammer pile driving) and bored piles (CFA) to drilled (DTH) piles – as well as, stone columns and for pre-augering.

The MOVAX MPL multi-tool piling leader is customised in accordance with customer-specific requirements:

- The same MOVAX MPL multi-tool piling leader can be utilised for different piling tasks with easily and quickly changeable tools ranging from vibratory pile drivers to impact hammers and rotary drives for pre-augering, CFA and DTH.
- The leader can be shortened to allow for low head room work; or when shorter piling or augering depths are required.
- The MOVAX MPL multi-tool piling leader is designed to work on a standard excavator without any changes thus enabling the excavator to be used for other purposes according to its original design.
- The local transportation requirements are taken into account in the customisation of the multi-tool piling leader.

	MPL-400	MPL-300
Type	Heavy duty, multi-purpose piling leader	Multi-purpose piling leader
Effective piling length/drilling depth	12 m	12 m
Tools	Vibratory pile driver Impact-type piling hammer Rotary drive for pre-augers CFA	Vibratory pile driver Impact-type piling hammer Rotary drives for pre-augers CFA DTH Vibrolance
Mounting (excavator class)	Boom (35-50 ton)	Boom (30-50 ton) Stick (35-50 ton)
Control	mControl+ Pro	mControl+ Pro
Information management	mFleetManagement mLogbook	mFleetManagement mLogbook

**NOTE!**

Tailor-made leaders are available for vibratory pile driver operation up to a maximum effective pile length of 16 meters. The maximum leader length is dependent on the excavator size and stability.

### MULTIPLE PILING TASKS



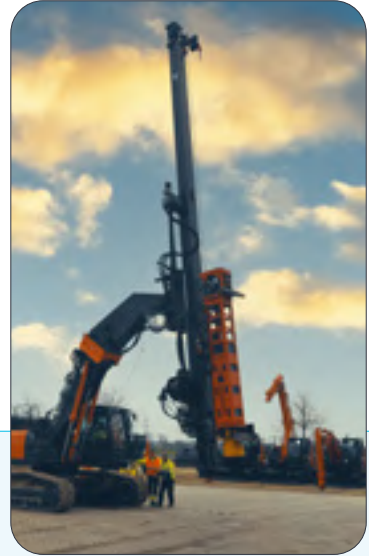
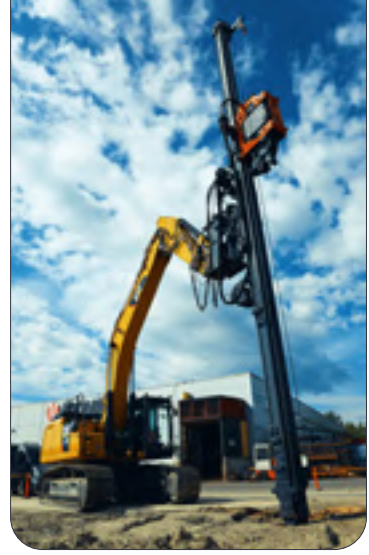



# MULTI-TOOL PILING LEADERS

## FEATURES

### EXCAVATOR-MOUNTED

- Excavator mounted, heavy duty multi-tool piling leader with tooling for a wide range of piling tasks.
- Available for a wide range of excavators starting from 30 tons and larger.
  - MPL-300 for 30 ton and larger excavators
  - MPL-400 for 40 ton and larger excavators
- Boom or stick mounted based on excavator stability. Delivered with excavator- and mounting specific adapter.
- Designed to work on any and all crawler-type excavators and rail roaders by utilising and commanding the standard auxiliary hydraulics and/or by connecting to the electronic control of the excavator - with all leader and tooling related hydraulics integrated onto the leader or tooling itself.

### MOVAX CONTROL SYSTEM

- Controlled with the MOVAX Control System, mControl+ PRO.

### MOVAX INFORMATION MANAGEMENT SYSTEM

- mFleetManagement for monitoring MOVAX piling equipment operation, performance and condition.
- mLogbook for monitoring and reporting the piling works including pile set criterion, CFA, etc. (optional).

### VERSATILE, MULTI-TOOL PILING SOLUTION

- Suitable for a wide range of piling applications, including
  - Driven piles (sheet piles, tubular steel piles, H-beams and precast concrete piles)
  - Bored piles (CFA)
  - Drilled piles (DTH)
  - Pre-augering
  - Stone columns
- A wide range of tooling, including
  - Vibratory pile drivers
  - Hydraulic hammers
  - Hydraulic double-acting piling hammers
  - Rotary drives for pre-augering
  - Rotary drives for CFA
  - Rotary drives for DTH
  - Rotary drive for vibrolance
- The same MPL can be used with multiple tools and for different piling and foundation tasks
  - Easy and quick change of tooling
  - Leader can also be detached enabling other (original) usage of the excavator.
- Scalable to different effective pile lengths/CFA, pre-augering & stone column depths.
- Versatile range of options based on piling technology and tooling;
  - Main winch(es)
  - Service winch(es)
  - Augers and lead augers
  - Pile and auger guides
  - Star cleaners
  - etc.

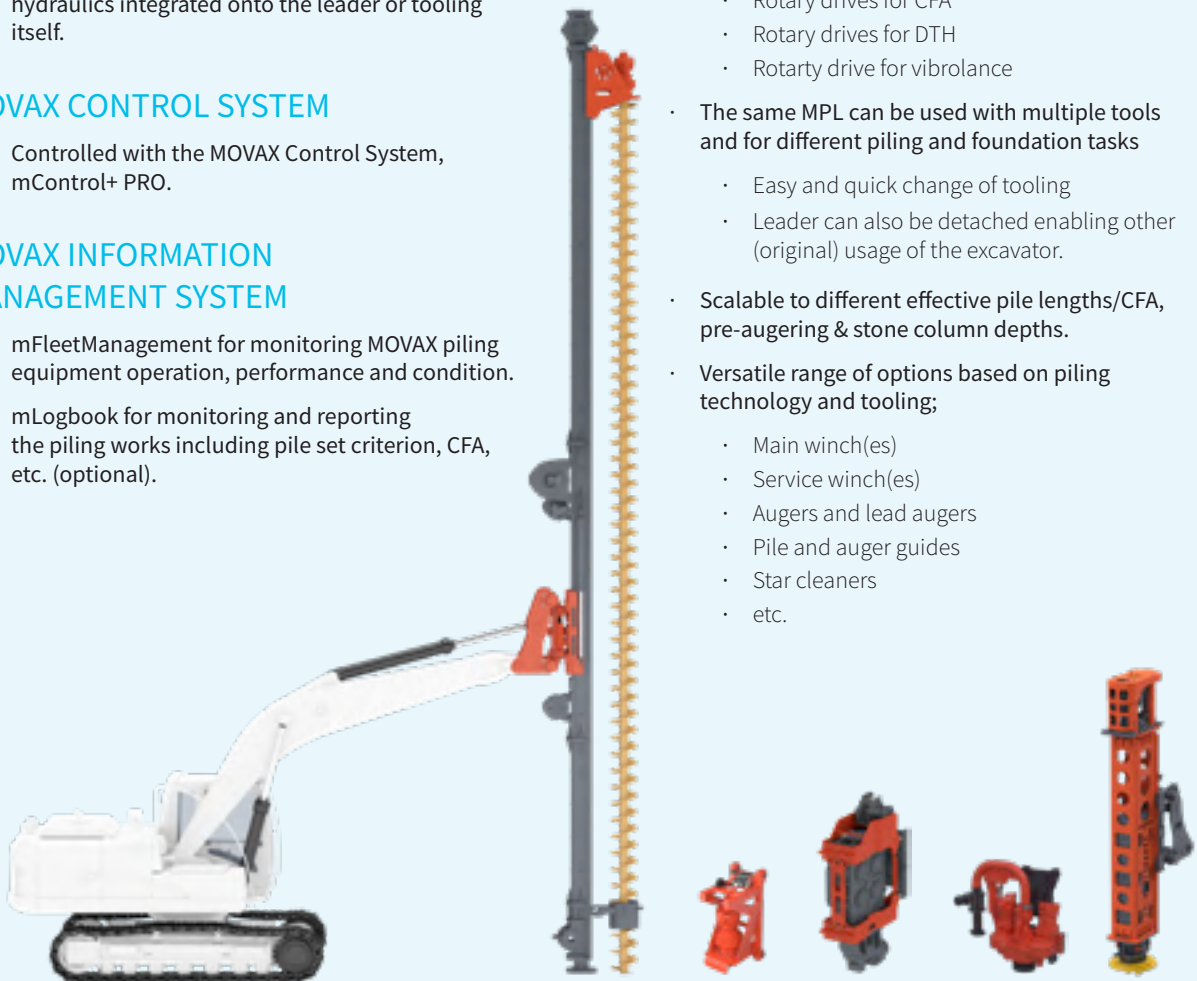

# MULTI-TOOL PILING LEADERS

## MOVAX MODULAR SYSTEM

MOVAX MPL Multi-tool piling leaders are of a modular design and thus suitable for a wide range of applications and piling technologies. The modularity applies to the tooling which can easily and quickly be changed to allow for the use of the same leader for multiple piling tasks – and to the piling depth: the leader can be shortened for instance for easier transportation and for low head site.

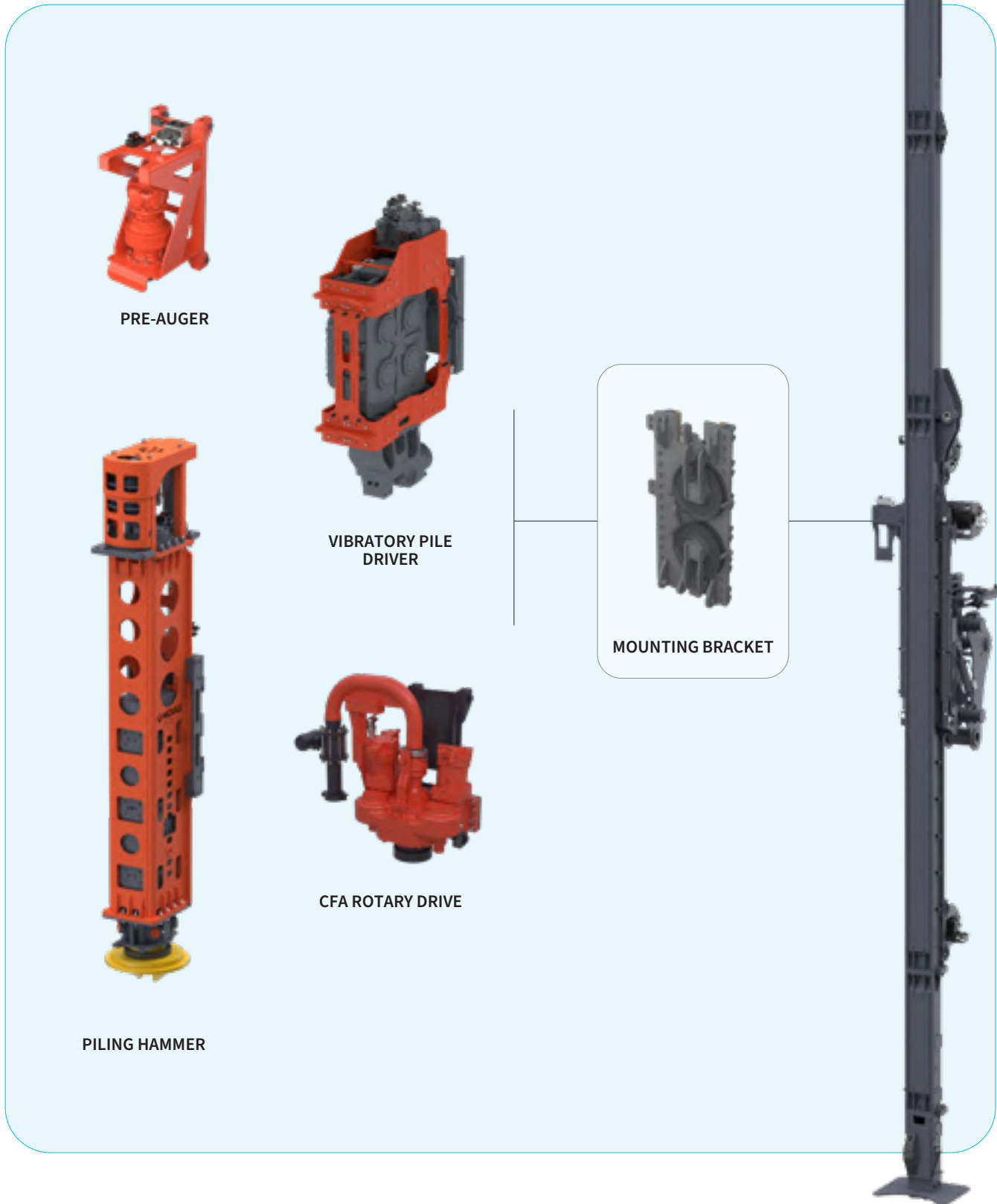

MOVAX MPL Multi-tool piling leaders are available in two basic configurations – MPL-300 and MPL-400 – which are suitable for different size excavators; depending on the excavator, which must always be checked for hydraulic power and stability, the MPL is either stick or boom mounted.

Depending on the piling application and tooling, MPL Multi-tool piling leaders are available with different options.

## OPTIONS



Main winch available with different lifting force (*1x or 3x winch line pull*).

MPL available also with optional service winch for lifting piles, augers and reinforcements.

Mounted directly onto excavator, stick or onto main boom (*depending on excavator class*).  
Excavator- and mounting-specific adapter included in the delivery.



Available with tool specific accessories; for example *CFA auger star cleaner*

Available with pile or auger guide for accurate positioning and verticality.  
Pile clamps either mechanical or hydraulic.



Lead augers and augers are available for different soil conditions and with different diameters.



# MULTI-TOOL PILING LEADERS

## SELECTION

The MOVAX MPL Multi-tool piling leader (MPL-300, MPL-400) and its associated tooling is selected based on the following:

- Excavator brand and model
- Piling technology & tooling options; multiple tooling options can be used on the same MPL multi tool piling leader
- Pile and augering dimensions (weight, length/depth, diameter, etc.)
- Soil and site conditions
- Transportation conditions & requirements

The MOVAX MPL Multi-tool piling leader is always customised based on the customer specific requirements.

### Excavator (carrier)

The excavator class (brand & model) effects the selection of the MOVAX Multi-tool piling leader configuration and the correct model (MPL-300 or MPL-400). The excavator class also effects the possible mounting options: boom or stick.

*note!*

*The excavator suitability (hydraulic power/stability) to be checked.*

### Piling technology & tooling options

The same MOVAX MPL Multi-tool piling leader can used for multiple piling technologies and with different tooling.



### Pre-auger rotary drive

MPL-300	Torque
T-5000	50 kNm
MPL-400	Torque
T-5000	50 kNm
T-10000	100 kNm
Options	
Augers & lead augers (300-600 mm)	- heavy duty, conical - rock, cylindrical
Auger guides	



## CFA Rotary drive

MPL-300		Torque
RH-52X		50 kNm
MPL-400		Torque
RH-52X		50 kNm
RHP-10		100 kNm
Options		
Augers & lead augers (300-600 mm)		- heavy duty, conical - rock, cylindrical
Auger drives		
Rotary drive		- electrical shifting - flushing head & pipe - pressure measuring device
Concrete flow meter		
mLogbook		



## Vibratory pile driver

MPL-300		Centrifugal force
TG-120		718 kN
MPL-400		Centrifugal force
TG-120		718 kN
TG-160		912 kN
Options		
Bottom clamp		pads for different type of piles
Pile guides		



## Piling hammers

MPL-300		Impact energy
DH-15		15 kNm
DH-25		25 kNm
MPL-400		Impact energy
DH-15		15 kNm
DH-25		25 kNm
DH-35		35 kNm
DH-45		45 kNm
Options		
Pile caps for different type of piles		
Pile guides		



# MULTI-TOOL PILING LEADERS

## TECHNICAL DATA

Model		MPL-300	MPL-400
Weight (without adapter & tool)	kg	5000-5250	7000-8000
Height	m	15	15
Forward inclination	°	0-20	0-20
Backward inclination	°	20	20
Tilt	°	8	8
Rotation (optional)	°	60	60
Winches			
Main winch	kN	57	120
Crowd winch	kN	57	120
Aux winch	kN	25	57
Crowd system			
Max. pull down force	kN	114	240
Max. extraction force	kN	171	240
Transport (w/o excavator)			
Length	mm	8600	8700
Width	mm	1800	2900
Height	mm	2000	2900
Weight (w/o tool)	kg	5300-5550	7000-8000
Excavator class	t	30-50	35-50
<b>Accessories/options</b>			
Mechanical or hydraulic guides			
Star (auger) cleaner			
Pulley system depending on tooling/application			

### NOTE!

Weights and dimensions - and other features -are tentative and provided for general information purposes only. The MPL leader will always be customised to meet customer specific requirements.

Excavator suitability (hydraulic capacity/stability) to be checked.



MPL in transit





# MULTI-TOOL PILING LEADERS, PILING HAMMER

## TECHNICAL DATA

Model		DH-15	DH-25	DH-35	DH-45
Total weight	kg	2800	3700	4900	5850
Ram weight	kg	1360	2060	3100	4000
Blows per minute	1/min	0-100	0-100	0-100	0-100
Impact energy	kNm	0-15	0-25	0-35	0-45
Drop height	m	0-1,2	0-1,2	0-1,2	0-1,2
Total height	mm	3850	4460	4460	4930
Frame width	mm	500	500	650	650
Transport width	mm	1200	1200	1200	1200
Transport depth	mm	1870	1870	1870	1870
Oil flow	l/min	80-120	80-120	80-120	80-120
Operating pressure	bar	150	200	250	280
Pressure relief set, max	bar	350	350	350	350

### Suitable piles

Sheet piles	U and Z, max length 12 m
H-beams	up to HEB500, max length 12 m
Tubular steel piles	up to Ø 508 mm, 12 m
	up to Ø 762 mm, 8 m
Precast concrete	up to 250x250 mm, max length 12 m



### Mounting bracket

The same mounting bracket can be utilized for different tooling mounted on the MPL multi-tool piling leader.



### Top cover

The same top cover can be used when mounting the MOVAX DH piling hammer directly onto the excavator.



### Lower frame



### Pile caps

Pile caps are available for different type of piles – ranging from sheet piles and tubular steel piles to precast concrete piles.



# MULTI-TOOL PILING LEADERS, VIBRATORY PILE DRIVER

## TECHNICAL DATA

Model		TG-120	TG-160
Total weight (transport)	kg	2460	2775
Total weight (operating)	kg	2385	2700
Dynamic weight	kg	1810	2100
Dynamic weight (excl. clamp)	kg	1230	1280
Height	mm	2500	2500
Depth	mm	1330	1330
Width	mm	460/410*	460/410*
Eccentric moment	kgm	12,6	16
Frequency	1/s	2300	2300
Line pull, max	kN	200	200
Amplitude	mm	14,5/20**	15,2 /25**
Centrifugal force	kN	718	912
Oil flow	l/min	240	300
Operating pressure, max	bar	350	350
Excavator class	ton	35-50	42-50

### Suitable piles

Sheet piles	U and Z, max length 12 m
H-beams	up to HEB500, max length 12 m
Tubular steel piles	up to Ø 508 mm, 12 m
	up to Ø 762 mm, 8 m

\* total/along piling line

\*\* with/without bottom clamp





# MULTI-TOOL PILING LEADERS, PRE-AUGER

## TECHNICAL DATA

Model		PD-50	PD-100
Total weight	kg	600	1000
Torque, max	kNm	50	100
Drilling speed	rpm	0-40	0-40
Connecting pin, hexagonal	mm	70	130
Oil flow	l/mm	240	240
Maximum pressure	bar	350	350
Pre-augering			
Depth	m	12	12
Hole diameter	mm	300-600	300-800
Lead augers	size, mm	300-600	
	type	heavy duty, conical rock, cylindrical	
Augers	length, m	3 or 6	
	size, mm	300-600	
	type	heavy duty, conical rock, cylindrical	
Connection			
Auger guide		Each auger diameter requires auger guide of corresponding size.	



### Lead augers



Heavy duty/conical



Rock/cylindrical

### Augers





# MULTI-TOOL PILING LEADERS, CFA

## TECHNICAL DATA

Model		RHP-10	RH52X
Total weight	kg	1800	1200
Torque, max	kNm	100	52
Drilling speed	rpm	0-50	0-50
Connection		bolt-on flange	
Oil flow	l/mm	250	250
Maximum pressure	bar	320	320
CFA			
Depth	m	12	12
Hole diameter	mm	300-800	300-600
Rotary drive	- electrical shifting - flushing head & pipe - pressure measuring device		
Concrete flow meter	mLogbook		
Lead augers	size, mm	300-600	
	type	heavy duty, conical rock, cylindrical	
Augers	length, m	3 or 6	
	size, mm	300-600	
	type	heavy duty, conical rock, cylindrical	
Auger guide	Each auger diameter requires auger guide of corresponding size.		



The Continuous Flight Auger (CFA) rotary drive is supplied with the following options:

### Options

1. Pressure measuring device
2. Flushing pipe
3. Concrete flow meter
4. Flushing head
5. Rotary head
6. Adaption kit for concrete pipe





# MULTI-TOOL PILING LEADERS, DTH

## TECHNICAL DATA

Model		GEONEX GR15	GEONEX GR50
Max. casing diameter	mm	323,9	610
Weight	kg	200	650
Length	mm	363	520
Width	mm	400	580
Height	mm	370	615
Thread connection		Api Reg 2 3/8" F, Api Reg 3 1/2" F, Api Reg 4 1/2" F	Api Reg 3 1/2" F, Api Reg 4 1/2" F, Api Reg 6 5/8" F, Hex heads
Max. oil flow	l/min	270	300
Max. oil pressure	bar	250	250
Max. torque, slow gear	kNm	min 7,5 / max 15	min 14 / max 55
Max. torque, fast gear	kNm	min 5 / max 10	min 9,3 / max 37,5
Max. rotation speed, slow gear	rpm	min 60 / max 30	min 57 / max 14
Max. rotation speed, fast gear	rpm	min 90 / max 45	min 85 / max 21

### Suitable DTHs (Down-the-Hole-Hammers)

Model		DTH size	DTH size
139,7	mm	4"	4"
168,3	mm	5"	5"
219,1	mm	6"/7"	6"/7"
273	mm	8"	8"
323,9	mm	10"	10"
406,4	mm	N/A	12"
508	mm	N/A	15"
610	mm	N/A	18"

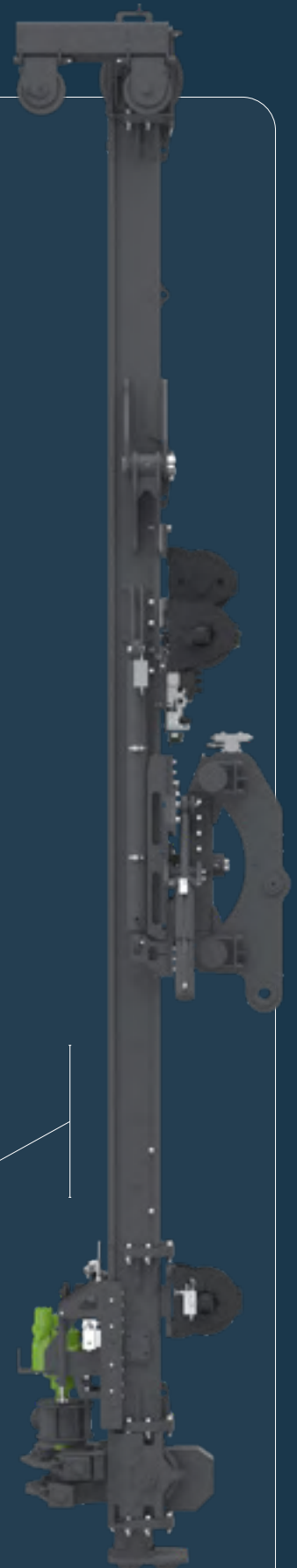



# MULTI-TOOL PILING LEADERS, VIBROLANCE

## TECHNICAL DATA

Model		BFS18-E8
Stone column diameter	mm	450-800
Treatment depth	m	5/7/8/9/10/11 <i>with modular extension tubes</i>
Hydraulic power	kW	110
Eccentric moment	kg/m	1,8
Operational frequency	Hz/RPM	50/3000
Centrifugal force, max.	kN	178
Oil flow, max.	l/min	189
Working pressure, max.	bar	350
Pull up, max.	kN	171
Pull down, max.	kN	114
Stone tank	m <sup>3</sup>	1,13
Total weight without gravel*	kg	3595-5310
Max. weight with gravel*	kg	5723-7822
Recommended gravel	mm	10-40
Modular sys. extension tubes		
2 meters	kg	585
4 meters	kg	1150
5 meters	kg	1345

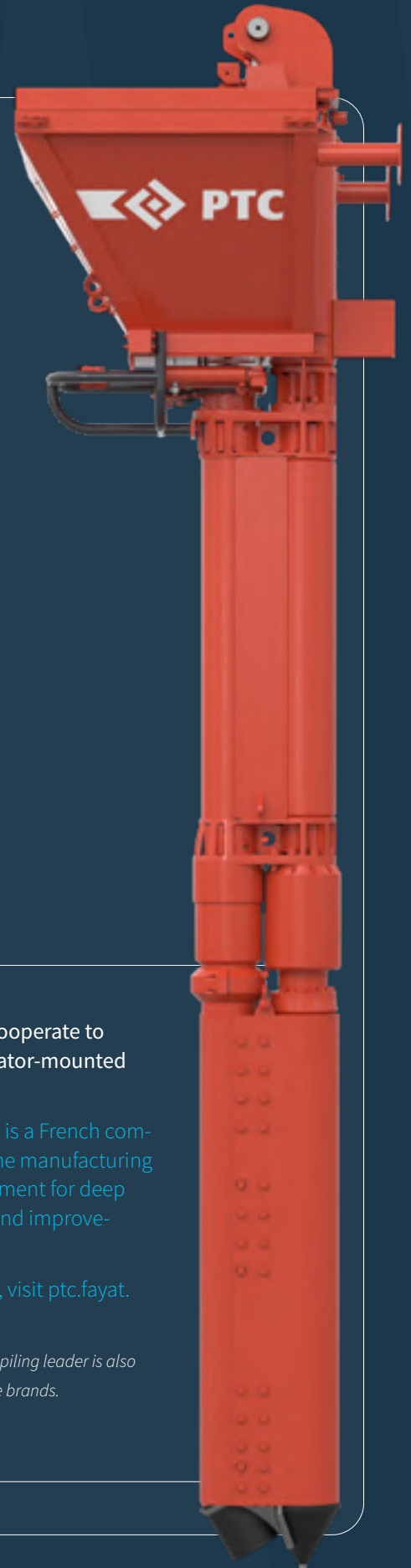

MOVAX Oy and PTC cooperate to provide a total excavator-mounted vibrolance solution.

PTC, founded in 1928, is a French company specializing in the manufacturing of construction equipment for deep foundations and ground improvement.

For more information, visit [ptc.fayat.com/en](http://ptc.fayat.com/en).

*note! MOVAX MPL Multi-tool piling leader is also suitable for other vibrolance brands.*





## INTRODUCTION

# SOIL IMPROVEMENT LEADERS

MOVAX excavator-mounted **MSL column stabilisation leaders** provides a versatile solution for soil improvement in a wide range of site and soil conditions when utilising dry binder material.

MOVAX excavator-mounted **MJL jet grouting leaders** provides a versatile solution for soil improvement in a wide range of site and soil conditions when utilising wet binder material.

The MOVAX soil stabilisation leader and its tooling are designed to work on a standard excavator with normal auxiliary hydraulics and are controlled with the MOVAX Control System. MOVAX MSL column stabilisation leaders and MJL jet grouting leaders are based on a modular concept and always customised to meet customer-specific requirements.



# COLUMN STABILISATION LEADERS, MSL

## FEATURES

### EXCAVATOR-MOUNTED

- Excavator mounted, heavy duty column stabilisation leader.
- Available for a wide range of excavators starting from 30 tons and larger.
- Boom or stick mounted based on excavator stability. Delivered with excavator- and mounting specific adapter.
- Designed to work on any crawler-type excavators and rail roaders by utilising and commanding the standard auxiliary hydraulics and/or by connecting to the electronic control of the excavator - with all leader and tooling related hydraulics integrated onto the leader or tooling itself.

### CUSTOM DESIGN BASED ON STANDARDIZED MODULES

- Maximum depth 20-25 meters depending on excavator size; due to modular design the leader can be shortened all the way down to 12 meter effective depth.
- Column diameters between Ø500–800 mm due to interchangeable mixer tip.
- Mixer tip vertical movement is achieved with two hydraulic winches.
- Binder feed at the top of the mixing rod to which a rotating joint for the binder hose is integrated.
- Roller mechanism on the rotary drive to apply torque and simultaneously allow feedthrough of the mixing tube.
- Integrated rotary drive and telescopic bottom foot at the end of the leader.
- Additional support for binder feed hoses and electric cables along the leader.

### MOVAX CONTROL SYSTEM

Controlled with the MOVAX Control System, mControl+ PRO.

### MOVAX INFORMATION MANAGEMENT SYSTEM

mLogbook for monitoring and reporting the column stabilisation work.

*MOVAX & ALLU co-operate to deliver a complete mass and column stabilisation solution.*

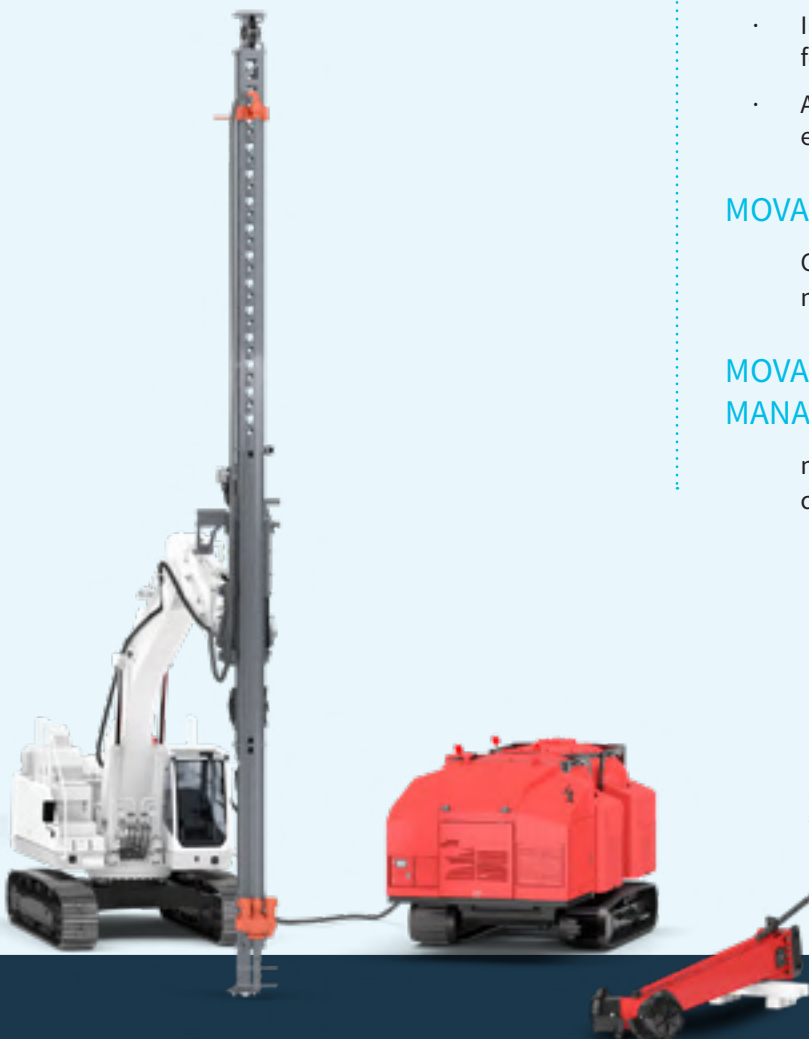

SOIL IMPROVEMENT

# COLUMN STABILISATION LEADERS, MSL

## TECHNICAL DATA

Model		MSL-300
Column depth	m	12-25
Column diameter	mm	500-800
Weight (w/o adapter)	kg	6500
Height	m	15-28
Tilt angle	°	+/- 8
Winches		
Main winch	kN	57
Crowd winch	kN	57
Crowd system		
Max. pull down force	kN	57
Max. extraction force	kN	57
Speed	m/min	0-30

Rotary drive		
Torque	kNm	20
Rotational speed	rpm	180-200

#### Features/instrumentation

- rotation speed
- rotation torque
- column depth/ascent rate
- driving angle

Mixer/mixer tip		
Mixer tip levels	pcs	4
Diameter	mm	500-800, nominal
Binder feed	kg/s	3,0
Compressed air, pressure	bar	10
Compressed air, flow rate	m <sup>3</sup> /min	6,5
Ascent rate	mm/r	20
Rotational velocity	rpm	180-200
Injection pipe		
length	m	21,3-26,3
inner diameter	mm	34
Support pipe		
length	m	21,3-26,3
size / wall thickness	mm	100 x 100 mm square/8 mm

#### NOTE!

Detailed technical data to be provided on case by case basis.  
Column depth and other technical data dependent on excavator size.

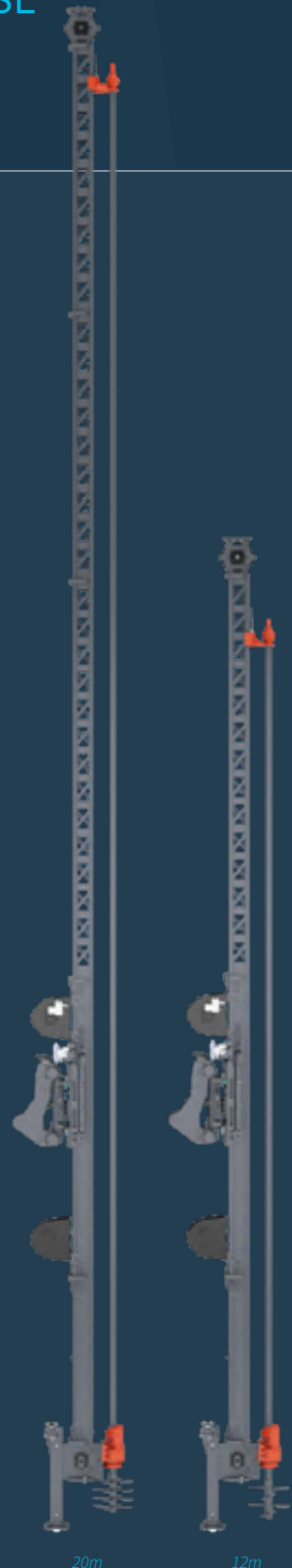

## COLUMN STABILISATION LEADERS, MSL

# MONITORING & REPORTING

The column stabilisation process is controlled and monitored using the **MOVAX mControl+ PRO** — a control system designed to communicate with external systems such as ALLU's DAC control system and different 3D systems (the connectivity will be developed on a case-by-case basis).

The control, monitoring and reporting system consists of the following systems which communicate with each other over the CAN-bus:

- MOVAX mControl+ control system
- MOVAX mLogbook reporting system
- ALLU DAC control system or other feed system
- Third party 3D system connectivity

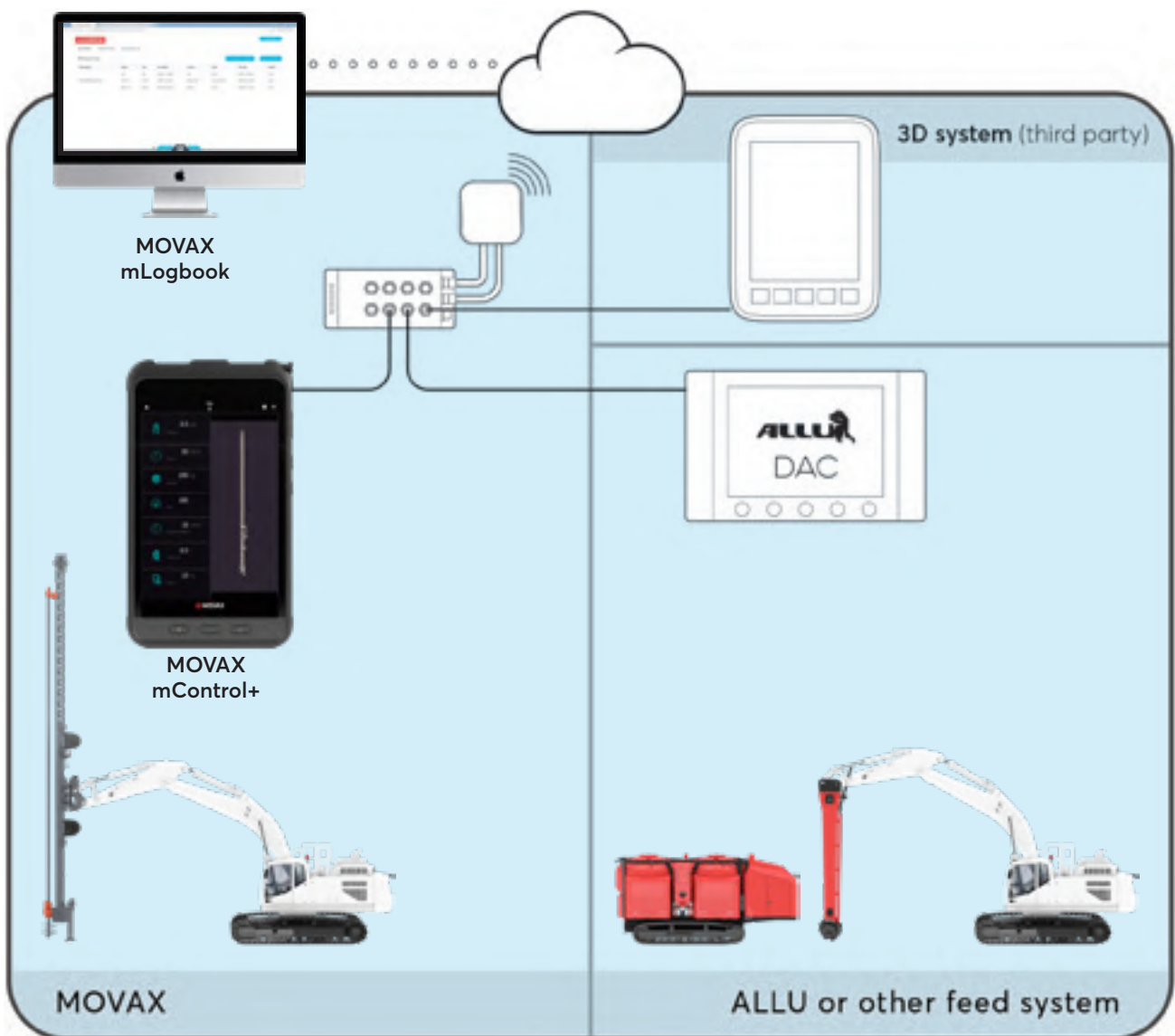



## PLANNING

The stabilisation drawings and plans are accessed through a 3<sup>rd</sup> party 3D-system. The planned location of mass stabilisation field and the stabilisation columns can be viewed by the operator on the display.

## MONITORING

The work flow is monitored using the MOVAX mControl+ and the 3<sup>rd</sup> party 3D-system.

The monitoring of location and positioning data is done with the 3<sup>rd</sup> party 3D-system display.

The mControl+ display is utilized to monitor all other stabilisation parameters, such as;

- **Column stabilisation:** for example binder quantity per column, ascent rate and rotational speed
- **Mass stabilisation:** for example binder quantity, feed and mixing times

The results of the stabilisation work can be viewed on the displays of the MOVAX mControl+ and the 3<sup>rd</sup> party 3D-system. The realised positioning data is shown in the 3<sup>rd</sup> party 3D-system, whereas all other reported parameters can be found in the MOVAX mControl+ system.



## REPORTING

The mass and column stabilisation work is reported utilizing the 3<sup>rd</sup> party 3D-system as well as MOVAX mLogbook reporting system.

The data is sent from the mControl+ system to a cloud-based server, *mCloud* (servers are located in Finland), where all the information is stored. Users can access the data and ready-made reports can through a password-protected, web-based interface.

The MOVAX mLogbook-reporting system also includes efficient tools for printing (PDF-format) and exporting the data to, for instance, Microsoft Excel.



# JET GROUTING LEADER, MJL

## FEATURES

### EXCAVATOR-MOUNTED

- Excavator mounted, heavy duty jet grouting leader.
- Available for a wide range of excavators starting from 30 tons and larger.
- Boom or stick mounted based on excavator stability. Delivered with excavator- and mounting specific adapter.
- Designed to work on any crawler-type excavators and rail roaders by utilising and commanding the standard auxiliary hydraulics and/or by connecting to the electronic control of the excavator - with all leader and tooling related hydraulics integrated onto the leader or tooling itself.

### CUSTOM DESIGN BASED ON STANDARDIZED MODULES

- Maximum depth up to abt. 20 meters depending on excavator size; due to modular design the leader can be shortened all the way down to 9 meter effective depth.
- Drill rod diameter between  $\varnothing 90$ –127 mm.
- Drill rod vertical movement is achieved with hydraulic chain drive.
- Cement-based grout slurry is fed at the top of the mixing rod to which a rotating joint for the grout slurry is integrated.
- Hydraulic chuck on the rotary drive to grab and apply torque to drill rod.
- Additional support for grout slurry hoses and electric cables along the leader.

### MOVAX CONTROL SYSTEM

- Controlled with the MOVAX Control System, mControl+ PRO.

### MOVAX INFORMATION MANAGEMENT SYSTEM

- mLogbook for monitoring and reporting the jet grouting work.

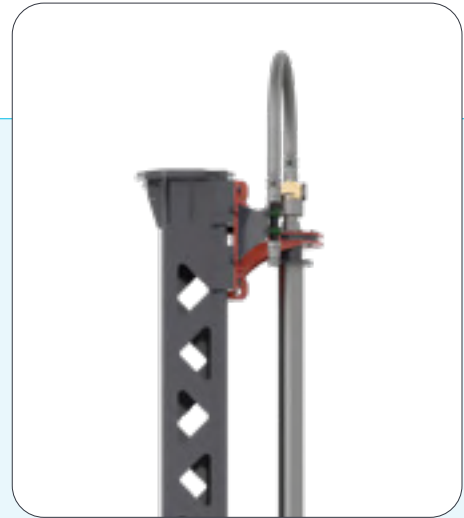

# JET GROUTING LEADER, MJL

## TECHNICAL DATA

<b>Model</b>		<b>MJL-300</b>
Weight (approx.)	kg	6000
Max. column depth (approx.)	m	20
Height	m	23
Tilt angle	°	±4
Leader stroke	mm	1700
Extraction force	kN	100
Pull down force	kN	100
Tool speed, extraction	m/min	0-20
Tool speed, pull down	m/min	0-20
Rotary drive vertical stroke	m	9

<b>Rotary drive</b>		<b>Eurodrill RH24X</b>
Torque	kNm	21
Rotational speed	rpm	0-170
Rod diameter	mm	Max. 127
Grout connection	"	1 to 1 ½
Excavator mounting		Main boom mount





*mControl+ is always installed so that the original functionality of the excavator is maintained – ie. no changes are made to the excavator and it can be used for all its other intended or original usage.*

# INTRODUCTION

## MOVAX CONTROL SYSTEM

The MOVAX Control System, **mControl+**, links the carrier (excavator, rail roader or equal) with the MOVAX piling equipment. It is a vital and inseparable part of the MOVAX way-of-piling resulting in higher productivity, a high-quality end-result, the safety of the piling process - and ensures the maximum availability of the MOVAX piling equipment.

mControl+ controls the standard auxiliary pilot circuit of the excavator, which in turn controls the excavator's auxiliary hydraulics - thus controlling all the functions of the MOVAX piling equipment. mControl+ utilizes inclination and pressure sensors to monitor and control the operation of the MOVAX piling equipment and the pile driving process.

The same mControl+ control system is used to operate all MOVAX piling equipment.

### Productivity & Efficiency

mControl+ enables the operator to efficiently and accurately control the MOVAX piling equipment for higher productivity.

mControl+ is available in two versions:

- mControl+ PRO with automatic control
- mControl+ LITE

The oil flow to different functions of both the MOVAX piling equipment and the excavator is automatically optimised by the mControl+ system, as required during the pile driving process.

This also results in the highest possible fuel efficiency and economy.

### Precision & Accuracy

Smooth movements, precision and accuracy of the pile installation are achieved with the proportional control of mControl+.

mControl+ also displays vital information about the pile driving process, supporting the operator in achieving not only efficiency, but precision and accuracy also.

### Safety

The operational and safety-related parameters of the MOVAX piling equipment are set and monitored by the mControl+ system to ensure the utmost safety of the pile driving process.



*MOVAX Multi-tool piling leaders require mControl+ PRO*





## FEATURES

### EXCAVATOR MOUNTED

Commanding the standard auxiliary hydraulic circuit of the excavator. The excavator's auxiliary pilot circuit is controlled optionally:

- Hydraulically, with a hydraulic valve block
- Electronically, with a PWM-module
- Through a CAN interface

Excavator brand & model specific 'accessory kits' are available for connecting mControl+ to the excavator.

### STATE OF THE ART, ADVANCED CONTROL SYSTEM

Based on proportional control for speed, precision and accuracy;

- **mControl+ PRO**, automatic control system with tip-control
- **mControl+ LITE**, basic control system

*note! MOVAX MPL Multi-tool piling leaders require mControl+PRO*

### EASY AND EFFICIENT DIAGNOSTICS

Available directly on the mControl+ display.

### ERGONOMIC AND INFORMATIVE USER INTERFACE

- Provides valuable information related to operation, performance, safety and availability
- Color display
- Easy-to-read graphical symbols
- User-friendly menus for calibration and performance optimization
- All functions are effortlessly controlled using the switches and thumb wheels on the control grips

### SAFETY

Integrated safety features.

### CONNECTIVITY TO MOVAX INFORMATION MANAGEMENT SYSTEM

- mFleetManagement
- mLogbook

*note! mLogbook requires mControl+PRO*

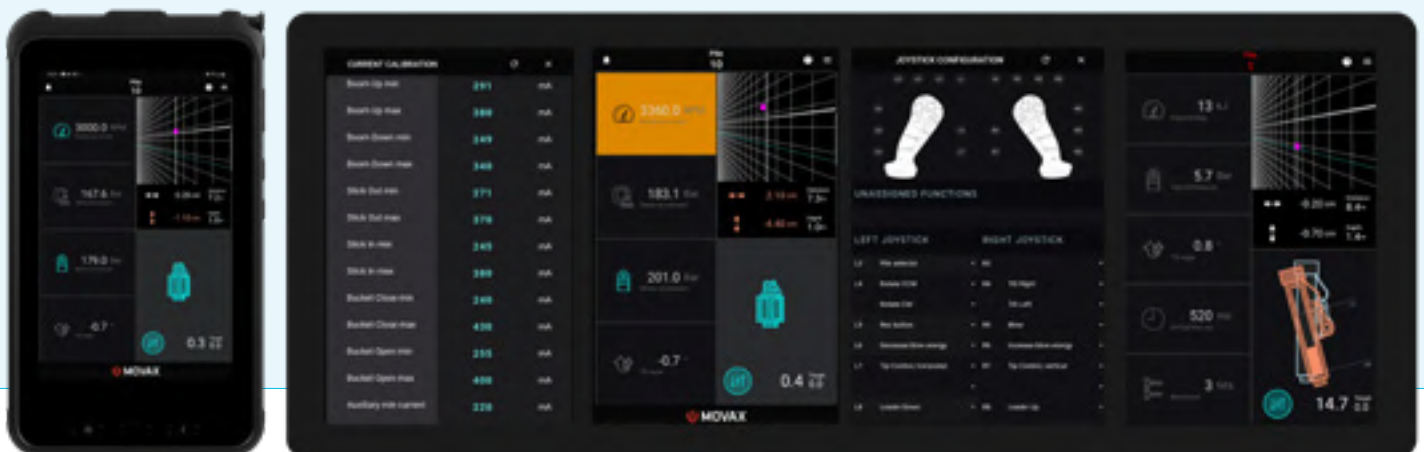

# INTRODUCTION

## mControl+ PRO

mControl+ PRO is a state-of-the-art, automatic control system featuring the *tip-control™* technology.

The tip-control's advanced computing technology works in tandem with boom- and stick-mounted angle sensors, and controls the excavator's auxiliary hydraulics utilizing either the proportional pilot valves, a PWM controller, or a CAN pilot circuit/interface.

mControl+ PRO is installed onto the excavator without making any changes to the original functionality of the excavator whatsoever.

*The automatic control* of the mControl+ PRO assists the operator in achieving a faster and more efficient, high-quality piling installation. The system also provides valuable information, further assisting the operator as well as ensuring the highest possible availability protecting the MOVAX piling equipment.

mControl+ PRO is utilized to control all MOVAX piling equipment - including SG side grip pile drivers, DH piling hammers, TAD/KB piling drills and MPM manipulators - and MPL multi-tool piling leaders and MSL column stabilisation leaders.

### mControl+ PRO

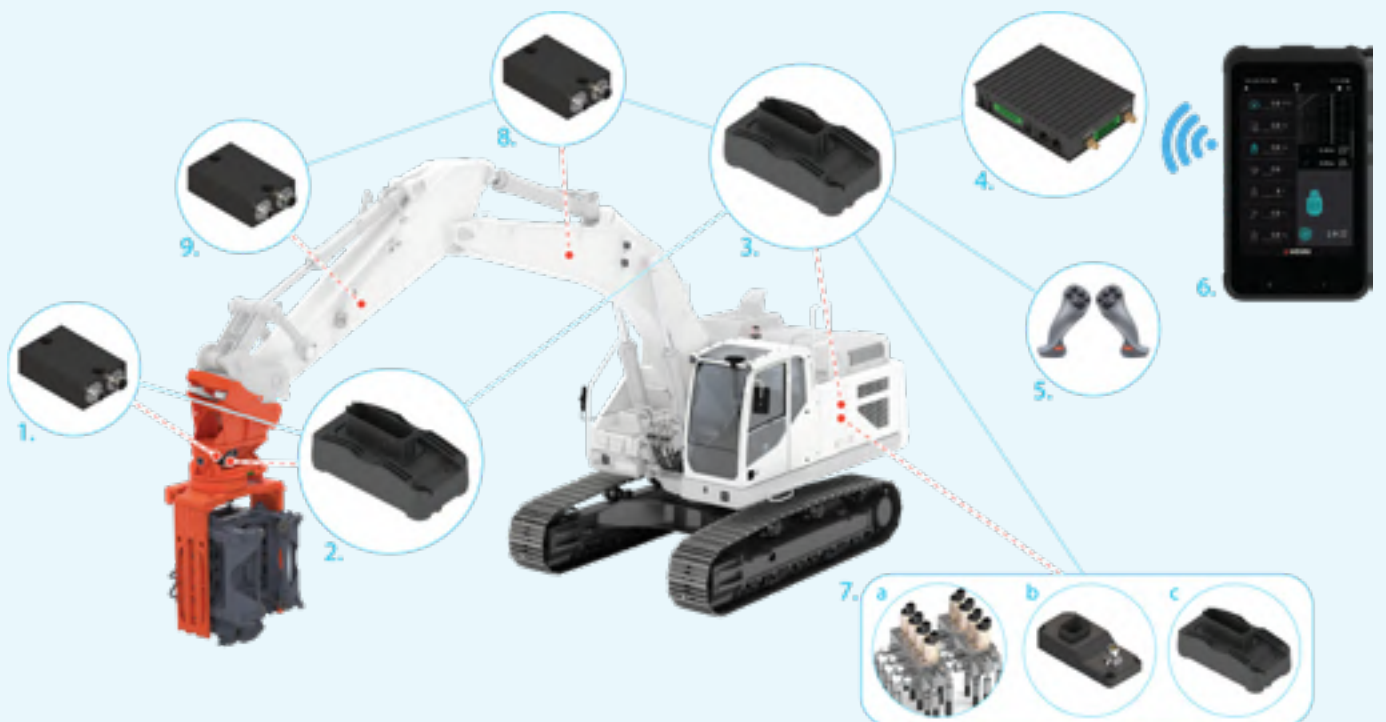

1. MOVAX Angle sensor (MxS)
2. MOVAX Module (MxM)
3. Excavator module (ExM)
4. MIMS Module
5. Control grips

6. mControl+ Display
7. Pilot circuit control
  - a) Hydraulic valve block
  - b) PWM Control
  - c) CAN Interface

8. Boom angle sensor  
In case of two-piece boom one additional sensor is required
9. Stick angle sensor

# mControl+ PRO

## FEATURES

### Automatic Control System

- Controls all the main functions of the MOVAX piling equipment and MOVAX customised solutions
- Automatic control for MOVAX SG side grip pile drivers and DH piling hammers based on state-of-the-art tip control technology

### Informative Control & Monitoring System

- Comprehensive information about the pile driving process - from verticality to refusal
- Detailed information for monitoring of equipment operation, performance and condition

### Display

- Android tablet, 8"
- Color display
- Ergonomic user interface for set-up/input data, monitoring and operation



### Control grips

- Ergonomic control grips with 2- or 3-rollers and buttons which allow complete operation with a single grip.
- Extra buttons and rollers are provided for accommodating functions from the excavator's original handles, as necessary.

### Control modules

- Excavator cab-mounted EXM controls the excavator's auxiliary hydraulics with either proportional valves, a PWM controller or a CAN bus control circuit.
- Factory installed MXM delivered with the MOVAX equipment, controls the hydraulic valves on the MOVAX piling equipment.



### Angle sensors

- Highly accurate angle and distance information designed for extreme vibration conditions.
- nextGen 360° angle sensors with gyroscopes for maximal accuracy.
- Additional sensor(s) for excavators with a two-piece boom

## mControl+ PRO

# AUTOMATIC CONTROL

mControl+ PRO is equipped with the advanced, automatic tip-control feature that makes for higher production rates and increased quality of installation by assisting the operator in achieving a faster and more precise piling process.

The automatic tip-control feature utilizes the power of computing and pre-programming combined with live sensory data enabling the operator to perform multiple simultaneous movements by single action.

**This ensures that the mounted MOVAX piling equipment travels vertically in a straight line by taking over the demanding parts of the excavator's boom control.**

The angle sensors are mounted on the carrier's boom and stick, the MOVAX piling equipment\* and the proportional pilot control of the excavator's auxiliary hydraulics.

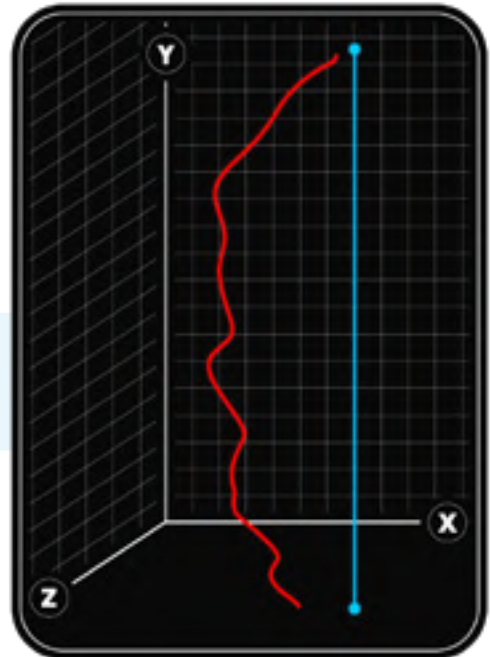

*\*available for MOVAX SG side grip pile drivers and MOVAX DH piling hammer.*



## mControl+ PRO

# AUTOMATIC CONTROL

The operator can pilot the boom assembly of the excavator in both directions, up and down (Y-axis) and forwards and backwards (X-axis), with single control grip roller commands – with a horizontally constant distance position, and the with the MOVAX side grip pile driver or MOVAX piling hammer parallel to the pile at all times.

The speed of the action can be adjusted fly-by with the proportional roller when the movement occurs. Highly accurate calibrations can be done in the mControl+Pro application, based on operator preference.

The **Y-axis** of the tip control-feature is utilized upon driving or extracting piles with a MOVAX side grip pile driver, or when adjusting the gripping position in order to drive the pile further into the soil.

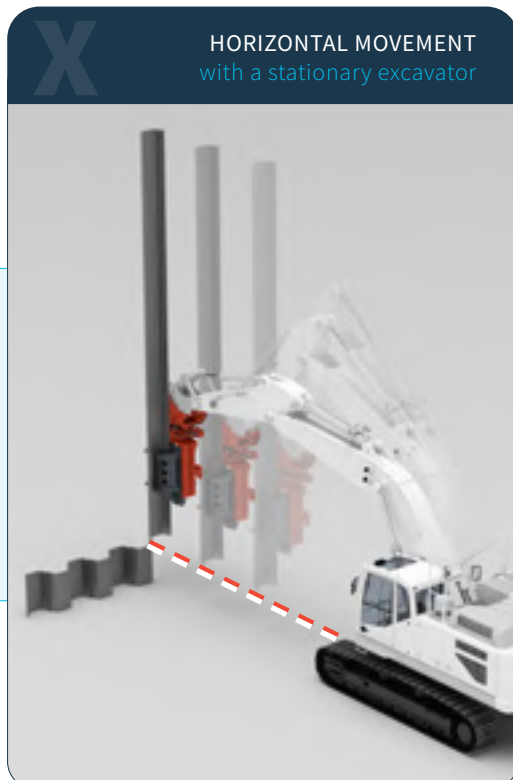

The **X-axis** of the tip control-feature comes into play when steady and accurate horizontal movement is required.

A particularly good example is the pitching of sheet piles: guiding the pile into the lock insert is faster when motion only happens on the X-axis, while maintaining a static position on the Y-axis.

## mControl+ PRO

# INFORMATION

mControl+ PRO provides comprehensive and essential information about the operation of the MOVAX piling equipment and the piling process itself, allowing the operator to monitor and optimize the operation for the best possible overall performance.

The mControl+ PRO provides the following key information (MOVAX SG side grip pile driver):

- **Angle.** Providing information about the verticality.
- **Frequency.** Helping the operator keep the performance on the optimum level.
- **Oil pressures** with warnings, to ensure the correct operation of the machine.
- **Clamp pressure**, providing extra safety to handling and driving process.
- **Gear oil temperature** with warnings, to monitor bearing temperatures and maintain the bearing lifetime.
- **Eccentric position**, provides information of the current eccentric moment on VA-models.
- **Position**, horizontal and vertical distances from the zero point, to increase the operators ability to perform.
- **Target angle**, for non-vertical driving
- **Refusal.** Displays a clear and visible warning when the refusal is reached during the pile driving process and ultimately stops the operation, thus protecting the MOVAX piling equipment.
- **Pile ID-number**, when using mLogbook.



*The information displayed is dependent on the MOVAX piling equipment in question.*





# INTRODUCTION

## mControl+ LITE

mControl+ LITE is a state-of-the-art control system that utilizes either proportional pilot valves, a PWM controller, or a CAN pilot circuit/interface to control the excavator's auxiliary hydraulics.

mControl+ LITE is installed onto the excavator without making any changes to the original functionality of the excavator whatsoever.

mControl+ LITE is utilized to control all MOVAX piling equipment, including SG side grip pile drivers, DH piling hammers, TAD/KB piling drills and MPM manipulators.

The LITE version of the system provides basic information about the operation, thus assisting the operator in the piling process.

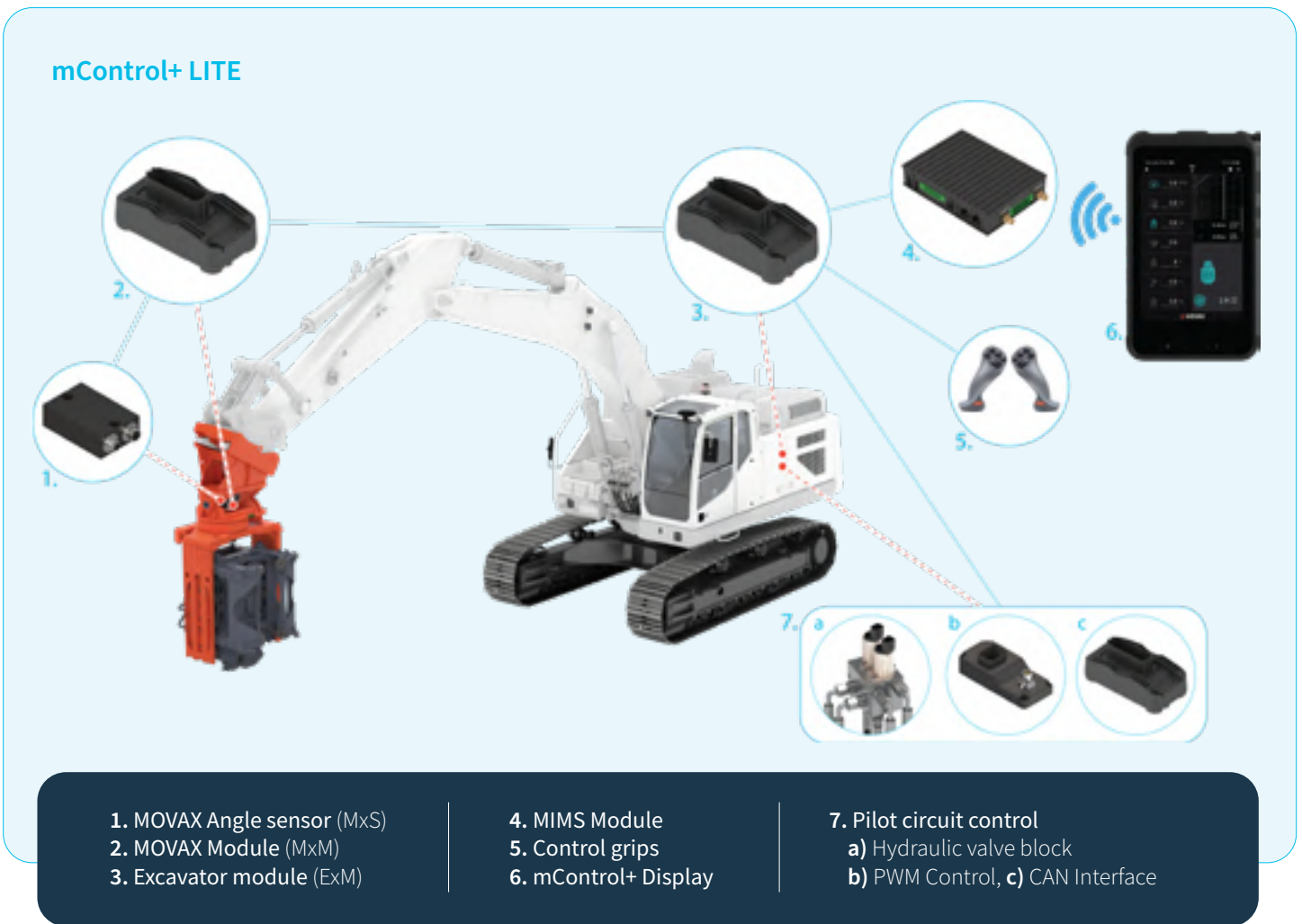

# mControl+ LITE

## FEATURES

### Basic Control System

- Controls all the main functions of the MOVAX piling equipment.

*mControl+ LITE can be upgraded to mControl+ PRO with separate upgrade kit.*

### Informative Control & Monitoring System

- Basic information about the pile driving process and for monitoring of equipment operation and performance.

### Display

- Android tablet, 8"
- Color display
- Ergonomic user interface for set-up/input data, monitoring and operation

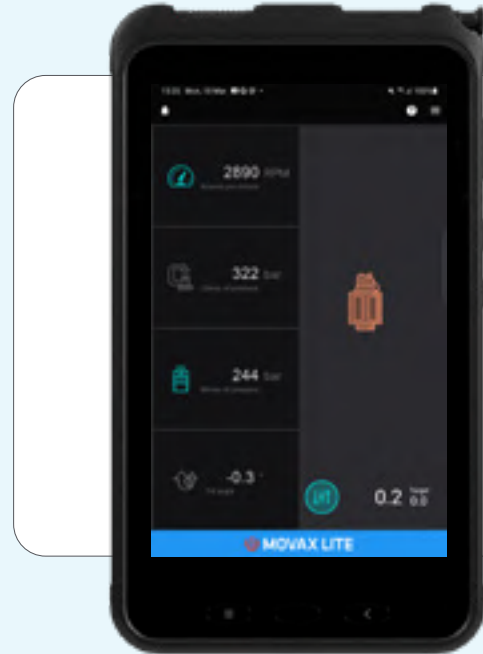

### Control grips

- Ergonomic control grips with 2- or 3-rollers and buttons which allow complete operation with a single grip.
- Extra buttons and rollers are provided for accommodating functions from the excavator's original handles, as necessary.



### Control modules

- Excavator cab-mounted EXM controls the excavator's auxiliary hydraulics with either proportional valves, a PWM controller or a CAN bus control circuit.
- Factory installed MXM delivered with the MOVAX equipment, controls the hydraulic valves on the MOVAX piling equipment.



# INTRODUCTION

# INFORMATION MANAGEMENT

MOVAX Information Management Systems (MIMS) provide essential information about the pile driving process – in order to improve the quality of the piling works and to save both time and costs in reporting - and about the MOVAX piling equipment itself – with the aim to maximize the availability.

## Data collection, -transfer and -storage

The MIMS hardware (HW), which is a part of the mControl+ MOVAX Control System and installed onto the excavator is utilised for automatic data collection and data transfer. The HW includes a fully integrated 4G/GPS-system providing the remote connection, and global positioning data. The information is sent to and stored in the MOVAX mCLOUD data storage. The information stored in the mCLOUD data storage is accessed through a web-based user interface. The information can also be accessed through the mFleetCare app.

MOVAX Information Management System is compatible with third-party global positioning systems such as Novatron/ MOBA, Trimble and Leica. When connected to a third party global positioning system it is possible to obtain also the exact location of the pile to be driven.

## Data suites



### mFleet Management

provides essential information about the operation, performance and condition of the MOVAX piling equipment. mFleetManagement is designed to assist in troubleshooting, diagnostics and analysis - and for fast and efficient customer technical support.

### mLogbook

is a documentation and reporting tool which provides essential data related to the piling process and the piling or foundation project.





# mFleetManagement

## FEATURES

The mFleetManagement-data suite provides basic operational, real-time information about the MOVAX piling equipment as well as the general global positioning (GPS) data of the MOVAX piling equipment and the excavator it is connected to. The information can be accessed remotely for adjustment and calibration – and for instance to provide operational guidance and support – as well as for trouble-shooting and quick problem-solving.

mFleetManagement also provides information for the prediction of maintenance requirements thus enabling preventive maintenance with the intent to maximize the availability of the MOVAX piling equipment.

The information can furthermore be utilised for instance for invoicing purposes, etc.

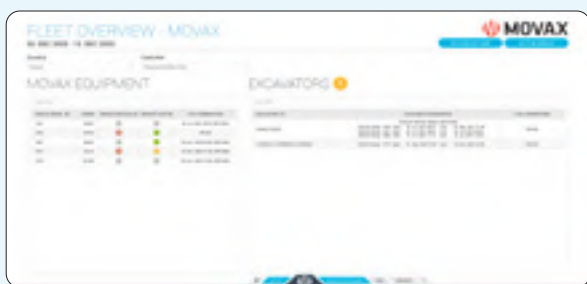

The **'Fleet Overview'** presents an overview of all the MOVAX piling equipment including all the excavators the MOVAX piling equipment is connected to. The 'Fleet overview' also provides a quick overview of the operating and service status of the entire fleet.

The MOVAX piling equipment to be monitored or analysed in more detail is selected from the 'Fleet Overview'.

The main **'Unit Overview'** provides the general information about the specific MOVAX piling equipment in question, its general geographical location, overall utilization hours, operating and service status.

More detailed information is obtained by moving from the 'unit overview' to the ready-prepared reports.



## Reports

The operational information is presented in an illustrative, easy-to-view and -browse format. The point-in-time or time interval to be reviewed or analysed can be selected flexibly. The information presented is providing a fast and flexibly overview of the operation, how the unit has been operated – especially in regards to the limits of some of the key operational parameters.

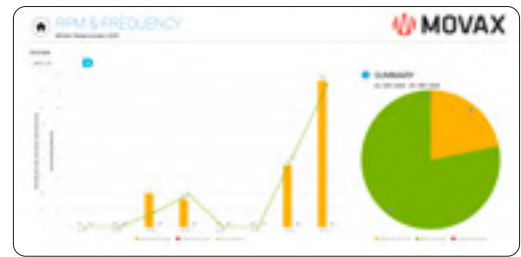

SG rpm/frequency

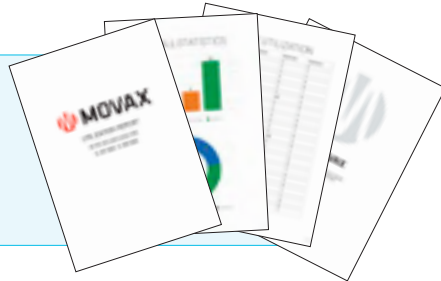

Based on for instance the **'Utilization hours'** a PDF-document for invoicing can be generated.



SG utilization

The ready-made reports include the following:

MOVAX SG Side grip pile drivers	MOVAX DH Piling hammers	MOVAX PA Pre-augers	MOVAX KB/TAD Piling drills	MOVAX MPL Multi-tool piling leaders
Utilization hours	Utilization hours	Utilization hours	Utilization hours	Utilization hours
RPM/Frequency	Back pressure	Working pressure	Working pressure	Working pressure
Working pressure	Refusal*	Back pressure	Back pressure	Back pressure
Back pressure	Service checks	Drain pressure	Drain pressure	Service checks
Drain pressure		Service checks	Service checks	
Clamp pressure				
Refusal*				
Service checks				

\*requires mControl+ PRO









# mLOGBOOK

## FEATURES

mLogbook is a documentation and reporting tool which provides essential data related to the piling process and the piling or foundation project.

The piling information is collected by the MOVAX Control System and stored in the MOVAX Control System's excavator module. To report the piling works the operator only has to input the pile number, the system will take care of the rest. Data concerning site and pile information is added by the user (engineer or equal) and the system will generate automatically illustrative, ready-made reports - including both measured and calculated data - which provide essential information about the piling process and its quality.

mLogbook is compatible with commonly used global positioning systems such as Trimble, Novatron and Leica which adds also the positioning data to the pile reports. Optionally independent global positioning sensors (RTK GNSS) can also be provided to allow for the addition of the exact pile positioning data without a third party global positioning system.

### Project overview

Specific reports are generated for MOVAX piling equipment including MOVAX side grip pile drivers, MOVAX piling hammers, MOVAX piling drills and MOVAX multi-tool piling leaders including the associated tooling,

The 'Project overview' provides the information of all main projects and also sub-projects.

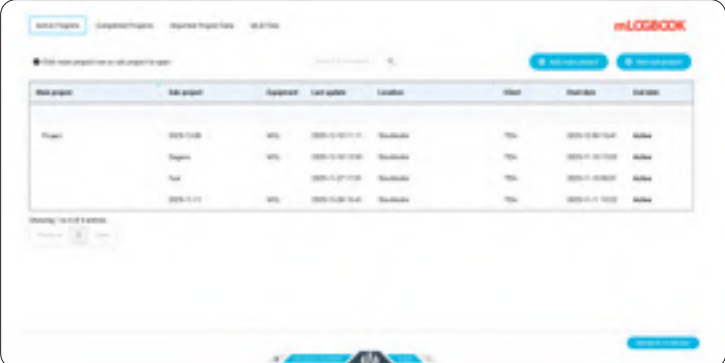

The screenshot shows the mLOGBOOK software interface. At the top, there are navigation tabs: 'Main Projects', 'Completed Projects', 'Reported Projects', and 'All Data'. The 'Main Projects' tab is selected. Below the tabs, there is a search bar and two buttons: 'Refresh' and 'Export Data'. The main content area displays a table with the following columns: 'Main project', 'Sub project', 'Equipment', 'Last update', 'Location', 'Status', 'Start date', and 'End date'. The table contains four rows of data, each representing a different project or sub-project. The first row has a 'Main project' of 'Project 1', a 'Sub project' of 'Subproject 1', 'Equipment' of 'MOVAX', 'Last update' of '2023-10-27 11:11', 'Location' of 'Stockholm', 'Status' of '75%', 'Start date' of '2023-10-27 11:11', and 'End date' of '2023-10-27 11:11'. The second row has a 'Main project' of 'Project 1', a 'Sub project' of 'Subproject 2', 'Equipment' of 'MOVAX', 'Last update' of '2023-10-27 11:11', 'Location' of 'Stockholm', 'Status' of '75%', 'Start date' of '2023-10-27 11:11', and 'End date' of '2023-10-27 11:11'. The third row has a 'Main project' of 'Project 1', a 'Sub project' of 'Subproject 3', 'Equipment' of 'MOVAX', 'Last update' of '2023-10-27 11:11', 'Location' of 'Stockholm', 'Status' of '75%', 'Start date' of '2023-10-27 11:11', and 'End date' of '2023-10-27 11:11'. The fourth row has a 'Main project' of 'Project 1', a 'Sub project' of 'Subproject 4', 'Equipment' of 'MOVAX', 'Last update' of '2023-10-27 11:11', 'Location' of 'Stockholm', 'Status' of '75%', 'Start date' of '2023-10-27 11:11', and 'End date' of '2023-10-27 11:11'. Below the table, there is a section for 'Showing 1 to 4 of 4 entries' and a 'Filter' button.

Main project	Sub project	Equipment	Last update	Location	Status	Start date	End date
Project 1	Subproject 1	MOVAX	2023-10-27 11:11	Stockholm	75%	2023-10-27 11:11	2023-10-27 11:11
Project 1	Subproject 2	MOVAX	2023-10-27 11:11	Stockholm	75%	2023-10-27 11:11	2023-10-27 11:11
Project 1	Subproject 3	MOVAX	2023-10-27 11:11	Stockholm	75%	2023-10-27 11:11	2023-10-27 11:11
Project 1	Subproject 4	MOVAX	2023-10-27 11:11	Stockholm	75%	2023-10-27 11:11	2023-10-27 11:11



## SG project report

The mLogbook 'project report' includes all the information related to the piling or foundation project including pile type & dimensions, the depth to which the pile has been driven with the various tools and for instance in the case of load bearing piles also information related to the pile set.

Different parameters are reported for the different MOVAX piling equipment.

**mLOGBOOK**

**PROJECT REPORT**  
**SG**

<b>Main project</b>	Bridge construction	<b>MOVAX piling equipment</b>	SG-60, sn1462	<b>Operator</b>	Tom Jackson
<b>Sub project</b>	SE Exit			<b>Start date</b>	2020-05-13
<b>Location</b>	Hillington, London	<b>Pile type</b>	Sheet piles	<b>End date</b>	2020-05-31
<b>Customer</b>	Road constructors ltd	<b>Note1</b>			
<b>Contract number</b>	923000-A1				

Pile#	Position data	Pile type	Pile dimensions [mm]	Pile length [m]	Total depth [m]	Depth [m]	Angle (avg) [°]	Date
1	53°26'54.036"N 2°12'47.012"W	AZ 13-770	770	12	7.877	6.143	0,0	2020-05-13 13:25
2	53°26'54.037"N 2°12'47.012"W	AZ 13-770	770	12	9.274	8.189	-0,1	2020-05-13 13:56
3	53°26'54.038"N 2°12'47.012"W	AZ 13-770	770	12	11.926	10.121	0,4	2020-05-13 14:38
4	53°26'54.039"N 2°12'47.012"W	AZ 13-770	770	12	7.062	6.157	0,2	2020-05-13 14:58
5	53°26'54.040"N 2°12'47.012"W	AZ 13-770	770	12	6.907	4.763	0,0	2020-05-13 15:05
6	53°26'54.041"N 2°12'47.012"W	AZ 13-770	770	12	6.368	5.921	0,0	2020-05-13 15:19
7	53°26'54.038"N 2°12'47.012"W	AZ 13-770	770	12	11.926	10.121	-0,3	2020-05-13 14:38
8	53°26'54.041"N 2°12'47.012"W	AZ 13-770	770	12	6.368	5.921	0,0	2020-05-13 15:19
9	53°26'54.038"N 2°12'47.012"W	AZ 13-770	770	12	11.926	10.121	0,1	2020-05-13 14:38
10	53°26'54.041"N 2°12'47.012"W	AZ 13-770	770	12	6.368	5.921	-0,1	2020-05-13 15:19
11	53°26'54.038"N 2°12'47.012"W	AZ 13-770	770	12	11.926	10.121	0,2	2020-05-13 14:38
12	53°26'54.041"N 2°12'47.012"W	AZ 13-770	770	12	6.368	5.921	0,0	2020-05-13 15:19
13	53°26'54.038"N 2°12'47.012"W	AZ 13-770	770	12	11.926	10.121	0,1	2020-05-13 14:38
14	53°26'54.041"N 2°12'47.012"W	AZ 13-770	770	12	6.368	5.921	-0,1	2020-05-13 15:19
15	53°26'54.038"N 2°12'47.012"W	AZ 13-770	770	12	11.926	10.121	0,2	2020-05-13 14:38
16	53°26'54.041"N 2°12'47.012"W	AZ 13-770	770	12	6.368	5.921	0,2	2020-05-13 15:19
17	53°26'54.038"N 2°12'47.012"W	AZ 13-770	770	12	11.926	10.121	0,3	2020-05-13 14:38
18	53°26'54.041"N 2°12'47.012"W	AZ 13-770	770	12	6.368	5.921	0,1	2020-05-13 15:19
19	53°26'54.038"N 2°12'47.012"W	AZ 13-770	770	12	11.926	10.121	0,1	2020-05-13 14:38
20	53°26'54.041"N 2°12'47.012"W	AZ 13-770	770	12	6.368	5.921	0,3	2020-05-13 15:19
21	53°26'54.038"N	AZ 13-770	770	12	11.926	10.121	0,0	2020-05-13 14:38

### MOVAX SG side grip pile driver -report:

Penetration rate, Centrifugal force, Working pressure, Eccentric moment, RPM, Inclination

## DH project report

The mLogbook 'project report' includes all the information related to the piling or foundation project including pile type & dimensions, the depth to which the pile has been driven with the various tools and for instance in the case of load bearing piles also information related to the pile set.

Different parameters are reported for the different MOVAX piling equipment.

### mLOGBOOK

#### PROJECT REPORT

##### DH

Main project	Road Project	Equipment	DH, sn XXXX, SG, sn XXXX	Operator	
Sub project	312 Piles			Start date	2025-03-25 06:00
Location	Main Road	Pile type	Circular	End date	
Client	LEE	Note 312 Piles			
Contract number	XYZ				

Pile#	Pile id	Position data	Pile type	Serial number	Pile dimensions (mm)	Pile length (m)	Depth DH (m)	Total depth (m)	Blows DH (no)	Inclination avg (°)	Pileset criterion			Date	Time
											Energy (kNm)	Blows	Set (mm)		
1			Circular	2303	508	15	2.789	2.789	3151	-0.5	10102/13000	754/754	0.539/7.800	2025-03-25	14:06:29
15			Circular	2274	508	15	0.404	6.920	376	-0.6	21718/20000	376/754	0.404/15.000	2025-04-24	08:00:24
16			Circular	2274	508	15	0.317	5.133	501	-1.0	22642/20000	501/754	0.317/15.000	2025-04-24	08:11:42
17			Circular	2274	508	15	1.068	9.096	658	-0.8	23101/20000	658/754	1.068/15.000	2025-04-24	08:31:51
18			Circular	2274	508	15	0.010	8.757	29	0.2	16551/20000	29/754	0.010/15.000	2025-04-24	08:47:34
19			Circular	2274	508	15	0.418	4.551	515	-0.5	23168/20000	515/754	0.418/15.000	2025-04-24	10:05:17
20			Circular	2303	508	15	1.436	1.436	948	-0.7	20000/20000	754/754	1.143/15.000	2025-04-26	10:20:53
21			Circular	2274	508	15	0.603	3.217	688	-1.1	13420/20000	688/754	0.603/15.000	2025-04-24	10:42:21
22			Circular	2274	508	15	0.402	-10.710	388	-0.6	18979/20000	388/754	0.402/15.000	2025-04-24	10:45:54
23			Circular	2274	508	15	1.436	13.142	1354	0	20010/20000	754/754	0.844/15.000	2025-04-24	11:00:13

#### MOVAX DH piling hammer -report:

Penetration rate, Rate per blow, Drop height, Energy, Inclination

## CFA project report

The mLogbook 'project report' includes all the information related to the piling or foundation project including pile type & dimensions, the depth to which the pile has been driven with the various tools and for instance in the case of load bearing piles also information related to the pile set.

Different parameters are reported for the different MOVAX piling equipment.

### mLOGBOOK

#### PROJECT REPORT

Main project	CFA, Central	Equipment	CFA	Operator	
Sub project	500789			Start date	2025-07-04 10:02
Location	Central	Pile type	CFA	End date	
Client		Note			
Contract number					

Pile#	Pile id	Position data	Pile type	Serial number	Pile dimensions (mm)	Pile depth (m)	Inclination (°)	Concrete volume (m³)	Concrete pressure avg. (bar)	Start time	End time	Elapsed time	Date	Time
0			CFA		500	45.290	-1.9	20.41	1	14:44:30	14:40:53	1127:56:23	2025-06-25	14:44:30
1			CFA		500	11.730	-0.8	1.53	1	08:04:43	08:33:17	0:28:34	2025-07-21	08:04:43
2			CFA		500	11.430	-0.4	2.51	3	12:47:39	13:07:12	0:19:33	2025-07-21	12:47:39
3			CFA		500	13.050	-0.6	2.41	3	13:28:31	14:12:14	0:43:43	2025-07-21	13:28:31
4			CFA		500	12.910	-0.7	1.90	5	14:31:17	15:01:47	0:30:30	2025-07-22	14:31:17
5			CFA		500	11.240	-1.0	2.32	4	14:07:06	14:28:17	0:21:11	2025-07-22	14:07:06
6			CFA		500	14.310	-0.9	2.49	5	12:47:03	13:12:38	0:25:35	2025-07-22	12:47:03
7			CFA		500	13.590	-0.7	2.29	5	13:18:09	13:44:30	0:26:21	2025-07-22	13:18:09
8			CFA		500	13.170	-0.9	2.65	3	11:54:32	12:37:48	0:43:16	2025-07-22	11:54:32
9			CFA		500	7.800	-1.0	2.85	3	09:38:02	10:38:06	1:00:04	2025-07-22	09:38:02
10			CFA		500	11.270	-1.0	2.47	4	09:37:38	09:55:49	24:18:11	2025-07-22	09:37:38
11			CFA		500	18.030	-1.0	2.95	3	08:52:12	09:37:35	0:45:23	2025-07-22	08:52:12
12			CFA		500	11.230	-1.7	2.41	6	10:00:04	10:16:48	0:16:44	2025-07-23	10:00:04
13			CFA		500	14.470	-1.3	1.91	4	11:23:02	11:58:24	0:35:22	2025-07-23	11:23:02
15			CFA		500	14.920	-1.1	1.97	3	12:00:13	12:52:00	0:51:47	2025-07-23	12:00:13
17			CFA		500	11.200	-1.3	1.87	3	12:54:08	13:35:52	0:41:44	2025-07-23	12:54:08
18			CFA		500	12.610	-0.6	2.04	4	16:20:22	16:50:35	0:30:13	2025-07-21	16:20:22
19			CFA		500	11.260	-1.3	2.27	6	15:40:51	15:57:27	0:16:36	2025-07-21	15:40:51
20			CFA		500	11.400	-1.2	2.93	3	11:10:04	12:07:36	0:57:32	2025-07-21	11:10:04
21			CFA		500	11.440	-1.0	2.50	3	09:59:33	10:32:26	0:32:53	2025-07-21	09:59:33
22			CFA		500	11.770	-0.7	2.43	2	08:43:22	09:55:10	1:11:48	2025-07-21	08:43:22
23			CFA		500	11.490	-1.7	2.70	6	12:22:42	12:45:33	0:22:51	2025-07-21	12:22:42
24			CFA		500	13.280	-1.0	2.70	4	14:14:55	14:46:12	0:31:17	2025-07-21	14:14:55
25			CFA		500	13.980	-1.4	2.50	4	17:04:16	17:44:24	0:40:08	2025-07-21	17:04:16
26			CFA		500	13.370	-0.9	2.52	4	10:46:02	11:18:06	0:32:04	2025-07-22	10:46:02
27			CFA		500	11.150	-1.0	3.29	1	17:45:21	08:51:35	15:06:14	2025-07-21	17:45:21
28			CFA		500	14.280	-1.2	1.72	4	15:02:41	15:35:21	0:32:40	2025-07-22	15:02:41
29			CFA		500	11.190	-1.2	3.80	2	15:38:36	08:37:59	16:59:23	2025-07-22	15:38:36
30			CFA		500	14.130	-0.8	2.57	4	11:20:00	11:52:02	0:32:02	2025-07-22	11:20:00
31			CFA		500	15.040	-0.6	2.13	3	14:50:56	15:26:09	0:35:13	2025-07-23	14:50:56

#### MOVAX Multi-tool piling leader CFA -report:

Position data, Pile type, Pile dimensions, Pile depth, Angle, Torque, Concrete volume, Concrete pressure, Start time, End time, Elapsed time, Date

## MSL project report

The mLogbook 'project report' includes all the information related to the piling or foundation project including pile type & dimensions, the depth to which the pile has been driven with the various tools and for instance in the case of load bearing piles also information related to the pile set.

Different parameters are reported for the different MOVAX piling equipment.

### mLOGBOOK

#### PROJECT REPORT MSL

Main project	MSL, Downtown	Stabilization method	MSL	Operator	
Sub project	2025-07-07	Binder material	OIVA	Start date	2025-07-08 11:32
Location	Downtown	Jobsite data (measured)		End date	2025-11-18 18:30
Client	YKW	Total mass	8371.6 kg	Note	
Contract number					

Column #	Column ID	X-coordinate	Y-coordinate	Z-coordinate start	Z-coordinate end	Z-coordinate ground	Binder material	Serial number	Comment	Column diameter (mm)	Total depth (m)	Total amount (kg)	Amount (kg/m)	Pressure (bar)	Flow (kg/s)	RPM average	Extraction speed (mm/r) average	Feeding time (hh:min:ss)	Mixing time (hh:min:ss)	Date	Time
783301	B3.6221			23.39	32.14	32.67	OIVA	2525		800	8.749	628.2	71.8	0	3.16	123.5	24.68	00:02:40	00:06:45	2025-07-23	11:12:14
967607	D3.2575			22.56	32.43	33.05	OIVA	2525		800	9.877	692.4	70.1	0	2.71	123.5	20.69	00:03:34	00:03:34	2025-07-21	15:53:01
4450506	B2.19780			26.75	32.51	32.78	OIVA	2105		800	5.763	424.9	73.7	0.63	2.74	139.1	16.81	00:02:18	00:02:23	2025-07-23	12:05:24
5034700	B3.2375			23.10	32.80	33.32	OIVA	2525		800	9.705	692.1	71.3	0	3.11	121.4	25.06	00:03:13	00:03:13	2025-07-23	19:41:29
7826567	D3.1847			22.83	32.12	32.75	OIVA	2105		800	9.289	651.1	70.1	0.64	3.49	130.1	21.95	00:02:59	00:03:01	2025-07-16	16:40:12
9895390	D3.1959			23.49	32.61	33.09	OIVA	2105		800	9.128	611.7	67.0	0.63	3.20	129.4	22.13	00:02:54	00:03:00	2025-07-17	11:52:54
11280156	B3.5296			24.03	32.58	33.13	OIVA	2525		800	8.547	613.8	71.8	0	3.32	131.5	23.11	00:02:45	00:02:45	2025-07-23	14:09:19
18823674	B2.18370			26.19	32.33	32.88	OIVA	2105		800	6.139	424.4	69.1	0.61	2.83	150.4	19.42	00:02:05	00:02:12	2025-07-22	17:11:57
18994839	D3.3654			23.04	32.30	32.95	OIVA	2105		800	9.266	647.2	69.8	0.64	3.52	139.3	22.24	00:02:56	00:03:01	2025-07-16	16:49:13
22618622	D3.2484			22.36	32.48	33.18	OIVA	2105		800	10.113	721.2	71.3	0.63	3.75	125.8	22.84	00:03:08	00:03:16	2025-07-15	14:55:15
23157530	D3.2709			21.95	32.38	33.05	OIVA	2525		800	10.438	728.1	69.8	0	3.07	135.7	20.07	00:03:39	00:03:39	2025-07-09	09:06:58
24294361	B2.17677			26.29	31.57	33.33	OIVA	2105		800	5.280	332.3	62.9	0.63	3.15	127.2	20.64	00:01:45	00:01:37	2025-07-08	08:54:18
28007268	B2.19773			25.33	32.25	32.87	OIVA	2105		800	6.921	482.5	69.7	0.64	3.24	132.1	21.59	00:02:17	00:02:18	2025-07-21	18:57:12
29488997	D3.2770			22.22	32.46	33.05	OIVA	2525		800	10.233	721.7	70.5	0	2.97	127.7	22.91	00:03:47	00:03:47	2025-07-08	17:24:56

#### MOVAX Column stabilisation leader MSL -report:

Position data, Pile type, Pile dimensions, Pile depth, Angle, Torque, Binder amount, Feed pressure  
Ascent rate, Start time, End time, Elapsed time, Date

## SG pile report

Based on the project report it is possible to generate pile specific reports for each individual pile; and for each individual MOVAX piling equipment.

**mLOGBOOK**

**PILE REPORT**  
SG

**Pile# 14**

Main project	Main street, SG	Operator	SG
Sub project	160 Piles	Date	2024-04-23
Location	Main Street	Start time	15:19:00
Client	LTD	End time	15:26:11
Contract number		Elapsed time	00:07:11
Serial number			
Note			

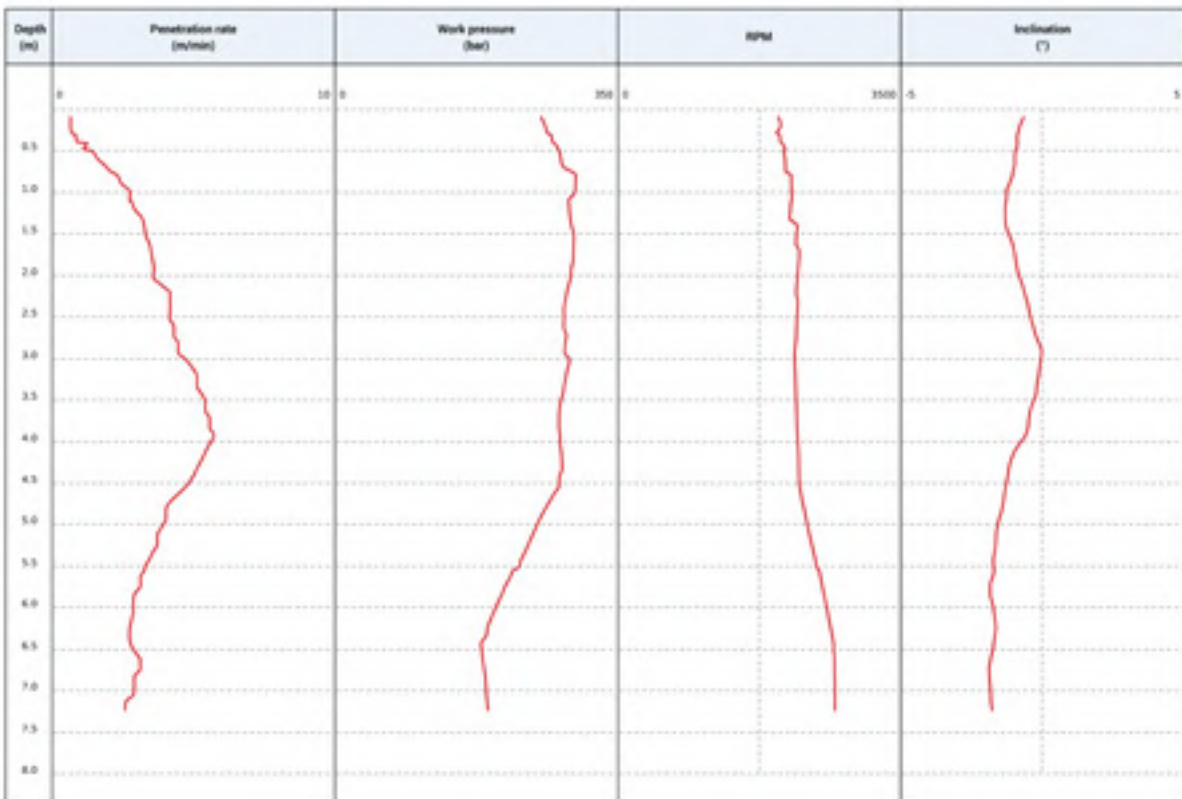

**MOVAX SG side grip pile driver -report:**

Penetration rate, Centrifugal force, Working pressure, Eccentric moment, RPM, Inclination

## DH pile report

Based on the project report it is possible to generate pile specific reports for each individual pile; and for each individual MOVAX piling equipment.

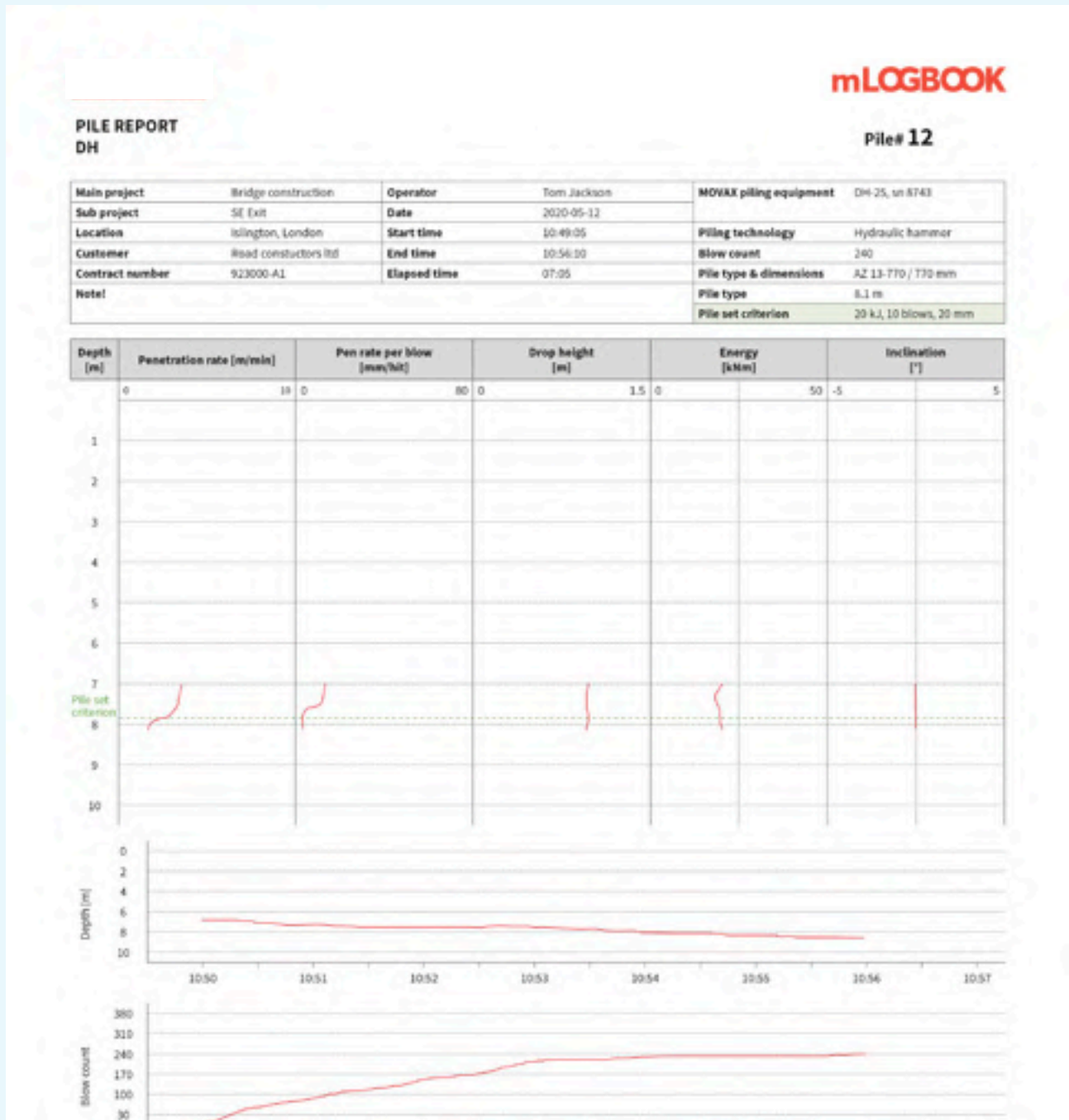

### MOVAX DH piling hammer -report:

Penetration rate, Rate per blow, Drop height, Energy, Inclination

## CFA pile report

Based on the project report it is possible to generate pile specific reports for each individual pile; and for each individual MOVAX piling equipment.

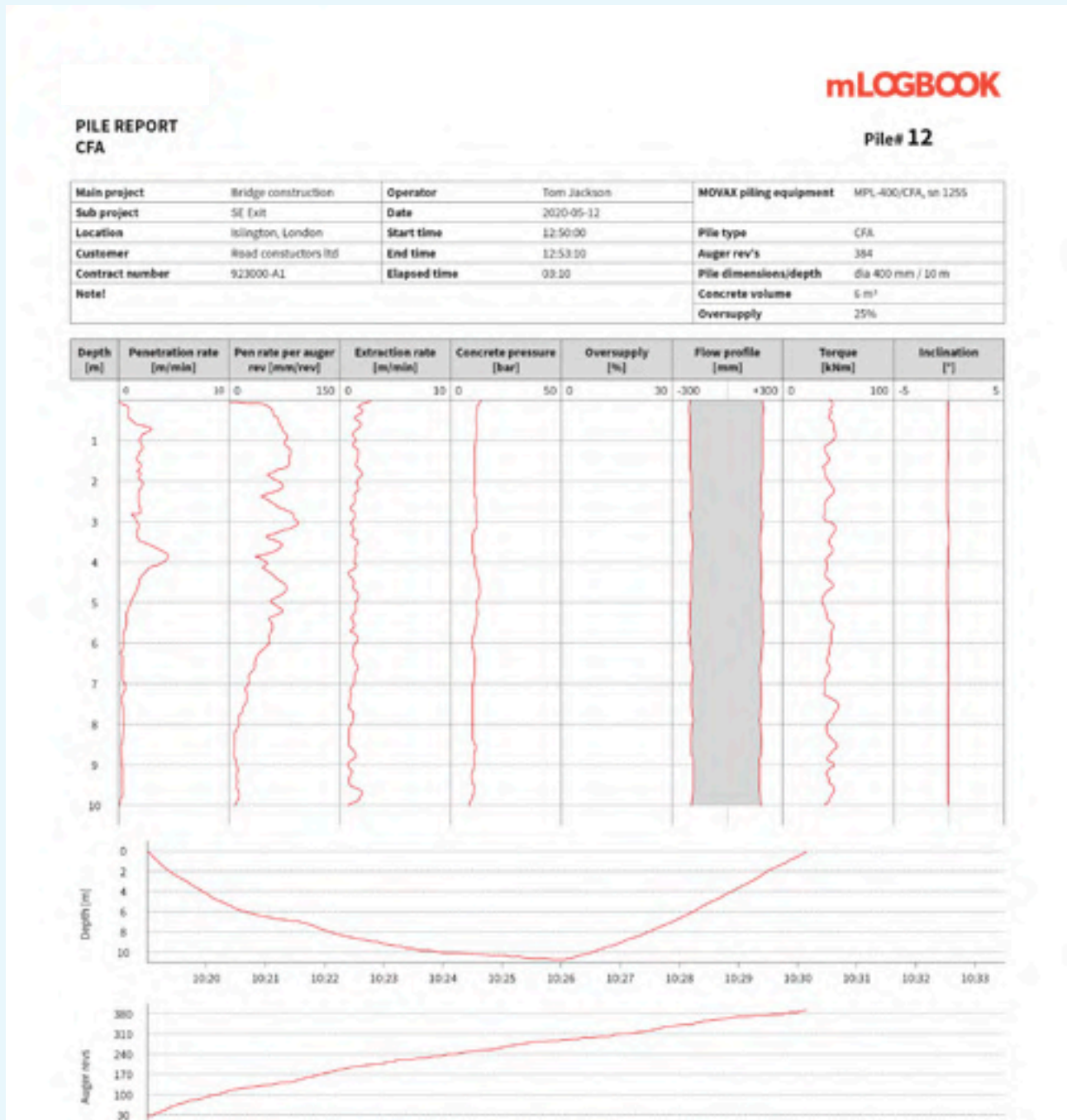

### MOVAX Multi-tool piling leader CFA -report:

Position data, Pile type, Pile dimensions, Pile depth, Angle, Torque, Concrete volume, Concrete pressure, Start time, End time, Elapsed time, Date

## MSL column report

Based on the project report it is possible to generate pile specific reports for each individual pile; and for each individual MOVAX piling equipment.

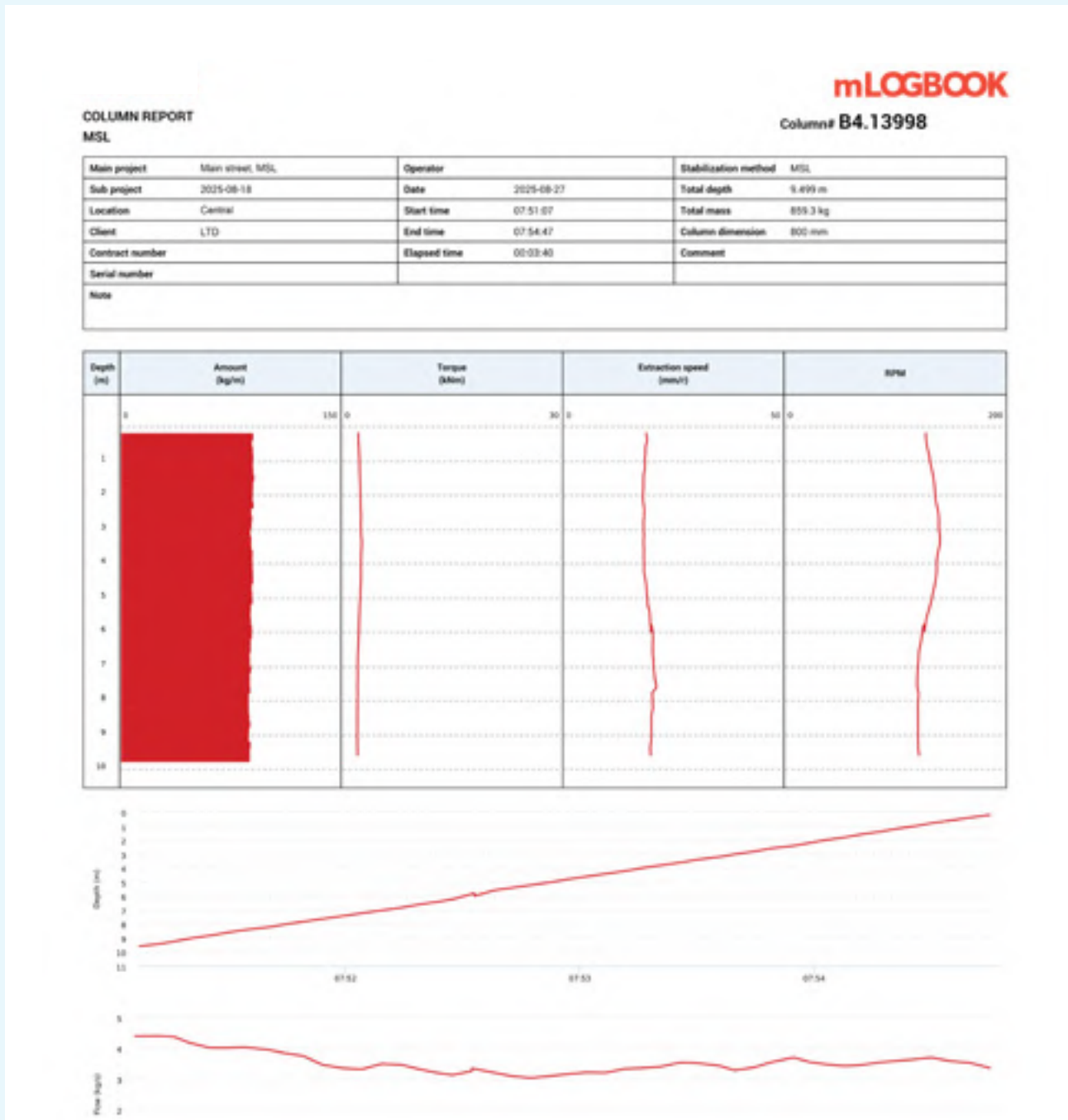

**MOVAX Column stabilisation leader MSL -report:**

Position data, Pile type, Pile dimensions, Pile depth, Angle, Torque, Binder amount, Feed pressure, Ascent rate, Start time, End time, Elapsed time, Date

# INTRODUCTION

## ADAPTERS

### Pin-connectors

Pin connectors consist of a welded adapter bracket with removable pins (Note! Pins are not included in Movax Oy's delivery, unless separately agreed upon). When connecting the MOVAX piling equipment to the excavator all mechanical, hydraulic and electrical connections are made manually.

Pin-connectors are based on the excavator brand and model. MOVAX Adapters are manufactured to match the specific dimensions of the excavator's bucket connection.



### (Mechanical) quick couplers

Quick couplers allow for a faster change of the MOVAX piling equipment or other tooling than for instance traditional pin connectors. When connecting the MOVAX piling equipment to the excavator, the mechanical connection is made by connecting the MOVAX adapter with the excavator's quick coupler. The hydraulic and electrical connections are made manually. MOVAX Adapters are custom-made in accordance with the dimensions of the excavator's quick coupler.



Typical mechanical quick couplers are, for example:

- **S-series** – S60, S70 etc. Note! MOVAX piling equipment and excavator specific MOVAX Adapters are customised according to the S-series standard.
- **Pin Grabber** – Miller etc.
- **CW-series** – Verachter etc.
- **SW-series** – Liebherr etc.

### Automatic quick couplers

Automatic quick couplers allow for an even faster change of MOVAX piling equipment and other tooling. When connecting the MOVAX piling equipment to the excavator all connections including the mechanical, hydraulic and electrical connections are made automatically.

MOVAX Adapters are manufactured according the quick coupler brand and model and its specific dimensions.

Typical automatic quick couplers are, for example:

- **OilQuick** – OQ60, OQ70, OQ80 etc.
- **Liebherr Solidlink (Likufix)** – SW33, SW48 etc.



## Other couplers & connectors

MOVAX Adapters for other type of couplers are manufactured according to the excavator's coupler or connector and its specific dimensions.

Typical couplers/connectors are, for example:

- **NTP**
- **Atlas**
- **Lehnhoff**
- **Liebherr 900**
- **Gjerstad**





## STATE-OF-THE ART MANUFACTURING

# QUALITY

MOVAX is made in Hämeenlinna, Finland utilising high-class materials, equipment and components – and modern, state-of-the-art production technologies and machinery ensuring the highest possible quality of manufacture.

Movax Oy's own production is supported by a proven, high quality network of partners. The state-of-the-art production facilities & machinery, long-term, established and reliable partners combined with optimized logistics ensure both quality and cost-efficiency – as well as fast, on-time deliveries.



### CERTIFIED MANAGEMENT SYSTEM

Movax Oy's Quality Management System is certified in accordance with ISO 9001-2015.





1137



PSALONEN OY

## SERVICES

# MOVAX mFleetCare

**MOVAX mFleetCare™** is a total service solution intended to maximise the productivity and the quality of the piling work when using MOVAX piling equipment. The goal of MOVAX mFleetCare is to ensure the maximum availability of the MOVAX piling equipment and to provide the operator with the required skills and best practices - and with superior support in all conditions and at all times – thus enabling the operator to perform the work with the highest productivity, accuracy and quality.

MOVAX mFleetCare addresses all aspects of ensuring the highest possible availability and the best use of MOVAX piling equipment. mFleetCare covers audits and inspections, preventive and corrective maintenance, training services for the continued growth of expertise and skills, efficient and fast on-site and remote support, installation and calibration services, as well as engineering and spare parts services.

MOVAX mFleetCare services are provided world wide by Movax Oy's own specialists and by a trained and certified network of partners. In addition, Movax Oy utilises the most modern IT-based solutions to provide support anywhere in the world, always and at any time.



### MOVAX mFleetCare



Audits



Preventive maintenance



Corrective maintenance



Training services



Installation services



Engineering services



Spare parts



## SERVICES

# GLOBALLY LOCAL

MOVAX supports its world wide customers centrally from the factory and engineering office located in Hämeenlinna, Finland AND through a network of local partners all over the world.

MOVAX local partners are both trained and certified, and thus highly skilled, in providing the necessary support and after sales services to local customers in order to ensure the highest possible availability and reliability of the MOVAX piling equipment at all times and under all circumstances.

MOVAX also cooperates continuously with end-users as well as with its local partners to continuously develop the MOVAX piling technology. The global coverage and expertise ensures that varying conditions and requirements are truly taken into consideration in an optimised manner.



WORLD-WIDE LOCAL SUPPORT  
IN MORE THAN 35 COUNTRIES

for MOVAX world wide partners kindly refer to:  
[movax.com/contact-us](http://movax.com/contact-us) or scan the QR code.



## MOVAX WAY-OF-PILING

# UNIQUE, INNOVATIVE & VALUE-ADDING SOLUTIONS

MOVAX way-of-piling™ provides a most efficient, fast, flexible and versatile, accurate, safe and reliable way-of-working which results in a higher productivity and thus significant overall time and cost savings in a wide range of piling and foundation – soil improvement - applications.

### BENEFITS

- **A total piling & foundation solution**  
*A complete range of piling equipment and customised solutions for driven, bored and drilled piles*
- **Unique, value-adding technology**  
*Fast. Efficient. Versatile. Accurate. Safe. Reliable.*
- **Globally proven technology & solutions**
  - Since 1993
  - Over 3000 deliveries
  - All over the world
  - Site & soil conditions from the arctic to the tropic
  - Numerous applications from rail, road and civil to waterways & piers, environmental & utilities
- **Globally supported sales and service**



HIGHER PRODUCTIVITY – SIGNIFICANT SAVINGS

Efficient. Fast. Versatile. Accurate. Safe. Reliable.



CIVIL



ROAD



RAIL



UTILITIES



ENERGY &  
ENVIRONMENT



WATERWAYS

# **MOVAX** way-of-piling

HIGHER PRODUCTIVITY - SIGNIFICANT SAVINGS  
*fast. efficient. versatile. accurate. safe. reliable.*

Movax Oy

Tölkkiäentie 10  
FI-13130 Hämeenlinna, Finland

Tel. +358 3 628 070  
marketing@movax.fi | movax.com

*Please refer to [www.movax.com](http://www.movax.com)  
for worldwide, certified partners.*

